

AIR-POWERED MATERIAL HANDLING  
**CATALOG**

# AIRFLOAT PRODUCTS



## SKIDS

- 10-11 [AIR SKID](#)
- 12-13 [AIR SKID: RIGGING KIT](#)
- 14-15 [AIR SKID: LIFT GLIDE](#)



## PLANKS

- 16-17 [AIR PLANK: ALUMINUM](#)
- 16-17 [AIR PLANK: STEEL](#)



## PLATFORMS

- 18-19 [UTILITY PLATFORM](#)
- 18-19 [UTILITY ROLL PLATFORM](#)
- 20-21 [AIR PLATFORM](#)



## TRANSPORTERS

- 22-23 [AIR TRANSPORTER](#)
- 24-25 [AIR ROLL MOVER](#)



LOCATED IN THE  
**MIDWEST**



SCALE OF MANUFACTURING  
**65,000 SQ. FT.**



FOUNDED IN 1967  
**55+ YEARS**



INVENTOR OF  
**AIR CASTERS**

## FULL SERVICE SOLUTION

Airfloat, established in 1967, pioneered air caster technology, enabling the efficient movement of heavy loads with minimal friction. Over the years, we have expanded our product line to serve diverse industries such as automotive, aerospace, manufacturing, and assembly lines. We continue to focus on engineering air caster solutions, emphasizing quality, safety, and performance to meet the demands of our global clientele.

- ***Diverse Product Line- Long Lasting Air Casters***
- ***Custom Engineering Solutions***
- ***Experienced Team***
- ***Commitment to Quality & Product Longevity***
- ***Support and Training Services***



### AIR CASTER TECHNOLOGY

Air caster technology utilizes a thin, pressurized film of air to lift and move heavy loads, distributing weight evenly and reducing friction, allowing for smooth, precise, and omnidirectional movement in a variety of applications.

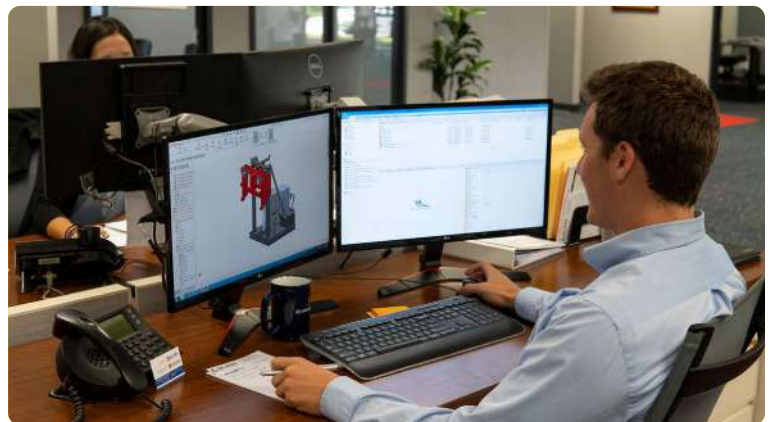

### ENGINEERING SUPPORT

Airfloat's engineering team leverages decades of expertise to design innovative, high-performance air caster systems tailored to meet specific operational needs.



# OUR PRODUCTS IN THE FIELD



### AIR SKIDS MOVE 55,000 LBS

An airplane engine rebuild facility needed to relocate their coordinate measuring machine (CMM) to a new bay. They are extremely heavy (over 20,000 lbs.) and require careful handling. Airfloat Air Skids prove to be the quick ideal solution.



### MANIFOLD ASSEMBLY LIFT GLIDES

A customer required a flexible method to move their subsea fluid power system of 10,000 pounds through their production line. Airfloat Lift Glides lift the frame off the ground and allows omnidirectional movement throughout the process.



### AIR SKIDS AT CUSTOMER SITE

A work stand manufacturer sought an alternative to wheels for moving newly-built aerospace work stands. The stands measured approximately 14'x14' and weighed 10,000 lbs., and Airfloat Air Skids provide a seamless solution.



### AIR SKIDS AT CUSTOMER SITE

A customer with a large open assembly area needed a way to move forestry vehicles through their production line. Airfloat Air Skids were chosen for their omnidirectional movement and to maintain a monument-free floor.

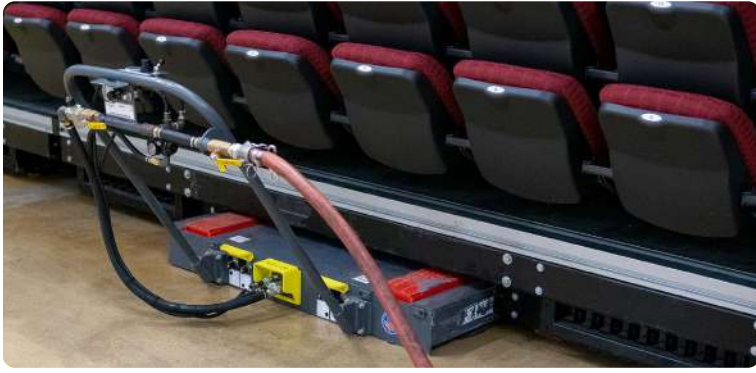

### **QUICK CHANGE BLEACHER MOVER**

The United Center, needed a way to quickly relocate bleacher sections. Using a custom Air Bearing Platform with lift, operators are able to move 30,000 lb. bleachers by hand, allowing the arena to reconfigure for ice hockey, basketball, or other entertainment events.



### **VALVE CASTING CMM TRANSPORTER**

A precision machining center required a system to move large castings to their coordinate measuring machine (CMM) quickly and easily. With the use of an Air Caster Transporter with integrated drives, our customer is able to move castings in excess of 25,000 lbs. with a single operator.



### **AIR SKIDS MOVING AIRPORT BOILER**

At one of the busiest international airports in the world, an industrial boiler needed to be replaced. By installing a set of high capacity Airfloat Air Skids underneath the 80,000 lb. boiler stand, operators were able to manually move the boiler out of commission to the maintenance area safely and effectively.



### **LOCOMOTIVE CAB ASSEMBLY**

A locomotive company needs to work on rail cars in an assembly line. Using an Air Bearing Transporter with drives and hydraulic lift, operators are able to drive the 20,000 lb. unit down the line and raise to working heights for better access.



### **NUCLEAR REACTOR CONSTRUCTION**

A nuclear power manufacturer needs to move and assemble superconductor modules for heat treatment. Using a custom Air Caster Transporter equipped with drives and electromechanical lift, the 250,000 lb. modules are easily positioned and raised.



# AIRFLOAT AIR CASTER



**POWERED BY COMPRESSED AIR**

**STANDARD CAPACITIES 305,000 LBS+**

**HEIGHT AS LOW AS 2.5 INCHES**

**OMNI-DIRECTIONAL MOVEMENT**

Air Casters, also known as Air Bearings, are a pneumatic component that provide an easy way to lift and move heavy loads by creating a cushion of air between the load and the floor. This allows for smooth, omni-directional movement, making it simple to position challenging loads. We use high-quality urethane diaphragms that are durable and resistant to wear, offering a cost-effective alternative to traditional wheeled systems.

- *Air Bearings Last for Decades in Ideal Environments*
- *Push Loads with a Single Operator, Compliant with Plant Standards*
- *Low Entry Cost*
- *Flexible For Changing Environments*
- *Safe and Stable When Deactivated*



6 AIR SKIDS FLOATING 80,000 LBS



AIR CASTER SLIDE-OUT TRAY

## **FLEXIBILITY WITH OMNI-DIRECTIONAL MOVEMENT**

Omni-directional movement allows the load to be moved in any direction – forward, backward, sideways, or even diagonally – without needing to rotate or reposition the equipment. This allows you to move and position your load with precision.

## **EASY MAINTENANCE WITH SLIDE-OUT TRAYS**

We've designed our Air Caster products for easy repair with slide-out trays to replace the Air Caster without removing the load - leading to minimal downtime and a quick turnaround to get back to moving heavy loads.



## AIR CASTER FLOORING CONDITIONS

Ideal floor conditions for Air Caster use include smooth, level surfaces with minimal texture, as rough or uneven flooring requires higher airflow and can impact performance. Floors should be flat, with transitions smoothed for continuous operation. Protrusions like bolts should be flush to avoid damage, and slight slopes can affect maneuverability.



**LEARN MORE  
ABOUT FLOOR  
CONDITIONS**

## AIR CASTERS AIR QUALITY

Air Casters perform at the highest level with clean dry air. The air doesn't need to be the highest quality of standards but moderately clean air. Moisture in the air supply can obstruct airflow causing wear on the caster system.

## REDUCED POINT LOADING BY 90%<sup>1</sup>

Air Casters distribute the load over a much larger area compared to wheels, dramatically reducing wear and tear on floors. They are an excellent solution for floors with lower load ratings.

## 66% LOWER DOWN HEIGHT<sup>1</sup>

Air Caster products have a much lower height compared to wheels, keeping the load close to the ground and reducing the risk of tipping.

## SAFE, SECURE LOAD CONTROL

The load can only be moved when the Air Casters are inflated. In an emergency, cutting the air supply causes the load to quickly and gently settle back down, ensuring it won't move.



1. Compared to standard wheeled systems with the same weight capacity



## EXPANDABLE SYSTEM

Our Air Caster systems offer customizable, expandable configurations, available in different sized sets to tailor load-handling capacity and positioning flexibility. This modular design allows facilities to adjust to varying load requirements.



## AIR PRESSURE

Air Casters generally operate at a standard pressure of 35 PSI with ideal floor conditions. However, as floor quality deteriorates (with roughness or unevenness), more air pressure is required to maintain lift and maneuverability.



# AIRFLOAT AIR SKIDS



6 AIR SKIDS FLOATING 80,000 LBS AT O'HARE AIRPORT

**POWERED BY  
COMPRESSED AIR**

**STANDARD CAPACITIES  
315,000 LBS+**

**HEIGHT AS LOW AS  
3 INCHES**

**OMNI-DIRECTIONAL  
MOVEMENT**

Air Skids, also known as Air Skates, are designed to be placed under, or mounted to the bottom of a load. When the Air Casters are inflated, they create a cushion of air that lifts the load, allowing for smooth, near-frictionless movement. Based on the load size and capacity, they can be arranged in standard sets of four or six. Custom arrangements can be used for various applications. Standard sets are available in a portable box with everything needed for the job.

- *Add Skids for greater load flexibility*
- *Easy maintenance with slide-out trays*
- *Optional Rigging Kit, portable box with everything needed for the job*
- *Distribute the load over a larger area, reducing the risk of floor damage*



## FLEXIBLE WITH A RANGE OF LOAD SIZES

Air Skids can be added or removed based on the load size, providing flexibility for higher capacities, complex shapes, and additional support. Talk with an Airfloat sales engineer to learn more.

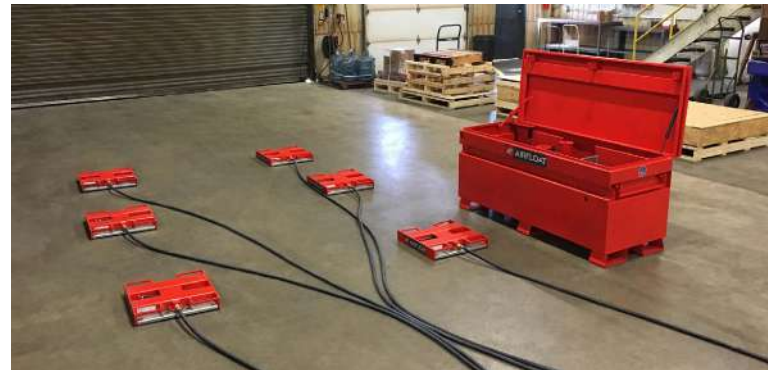

## ALL-IN-ONE RIGGING KIT

Containing everything needed for the job, it secures the Air Skids and equipment in a portable box. It fits in most truck beds and includes custom inserts and forklift pockets for easy relocation. For more detail, see page 10.

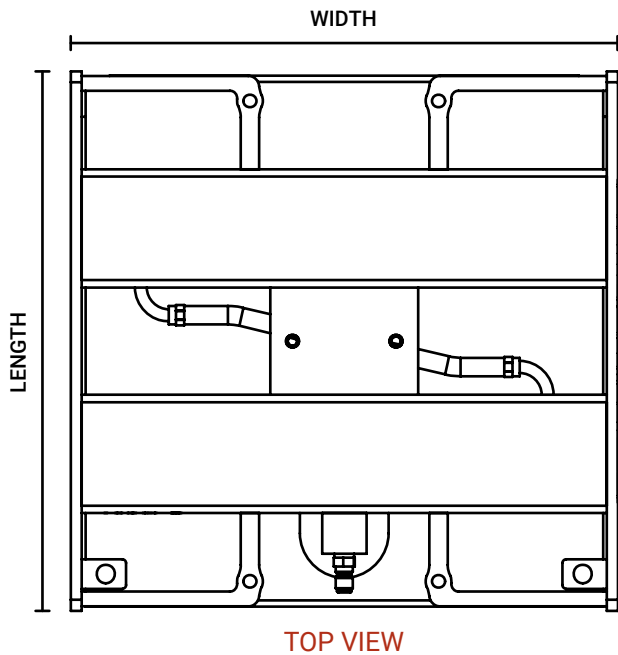

TOP VIEW

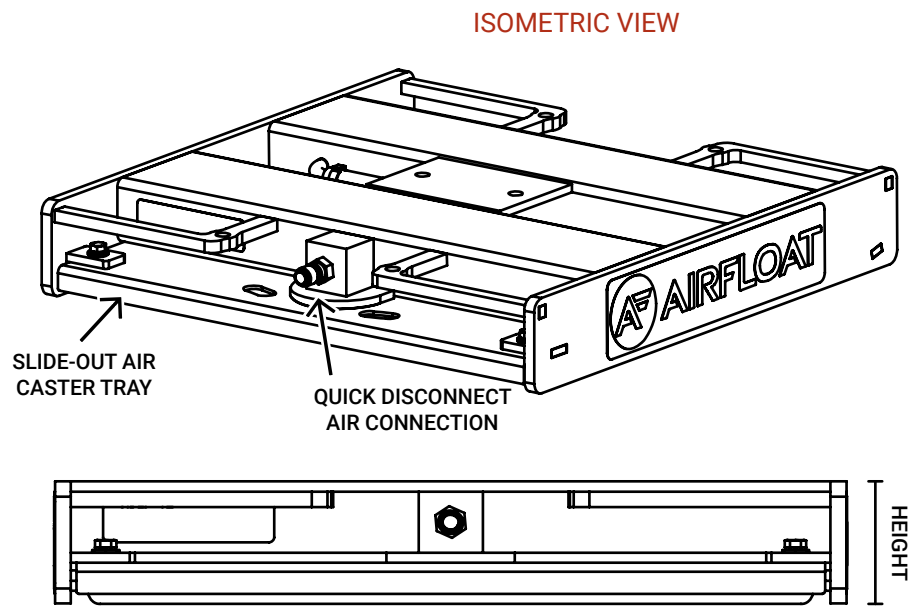

BACK VIEW

## SET OF 4 & 6 AIR SKID SPECIFICATIONS

MODELS	SET OF 4 SKIDS		SET OF 6 SKIDS		HEIGHT DEFLATED <sup>1</sup>	SKID SIZE L x W	WEIGHT 1x SKID
	CAPACITY	AIR FLOW	CAPACITY	AIR FLOW			
AF01012 12" CASTER	12,000 lbs 5,443 kg	44 SCFM 1,246 L/m	18,000 lbs 8,165 kg	66 SCFM 1,869 L/m	3 in 76 mm	13.25 x 13.25 in 337 x 337 mm	26 lbs 12 kg
AF01017 17" CASTER	25,000 lbs 11,340 kg	64 SCFM 1,812 L/m	37,500 lbs 17,010 kg	96 SCFM 2,718 L/m	3 in 76 mm	18.25 x 18.25 in 470 x 464 mm	44 lbs 20 kg
AF01020 20" CASTER	33,000 lbs 14,969 kg	72 SCFM 2,039 L/m	49,500 lbs 22,453 kg	108 SCFM 3,058 L/m	3 in 76 mm	21.5 x 21.5 in 546 x 540 mm	58 lbs 26 kg
AF01024 24" CASTER	50,000 lbs 22,680 kg	88 SCFM 2,492 L/m	75,000 lbs 34,019 kg	132 SCFM 3,738 L/m	3.5 in 89 mm	25.75 x 25.25 in 654 x 641 mm	98 lbs 44 kg
AF01030 30" CASTER	85,000 lbs 38,555 kg	112 SCFM 3,171 L/m	127,500 lbs 57,833 kg	168 SCFM 4,757 L/m	3.5 in 89 mm	31.75 x 31.5 in 806 x 800 mm	138 lbs 63 kg
AF01036 36" CASTER	125,000 lbs 56,699 kg	140 SCFM 3,964 L/m	187,500 lbs 85,049 kg	210 SCFM 5,947 L/m	4 in 102 mm	37.75 x 37.5 in 959 x 953 mm	235 lbs 107 kg
AF01048 48" CASTER	210,000 lbs 95,254 kg	188 SCFM 5,324 L/m	315,000 lbs 142,882 kg	282 SCFM 7,985 L/m	5 in 127 mm	50 x 49.5 in 1,270 x 1257 mm	430 lbs 195 kg

1. Inflated height adds approximately 1/16th in (1.6mm) to 1.875 in (47.6mm), depending on model, load weight, and air flow.

### INCLUDED WITH AIR SKID SET

PRODUCT	QUANTITY
AIR SKIDS	4 or 6
AIR SKID CONTROLLER	1
DEADMAN PENDANT	1
32FT SINGLE HOSE	4 or 6
SPARE AIR CASTER	1

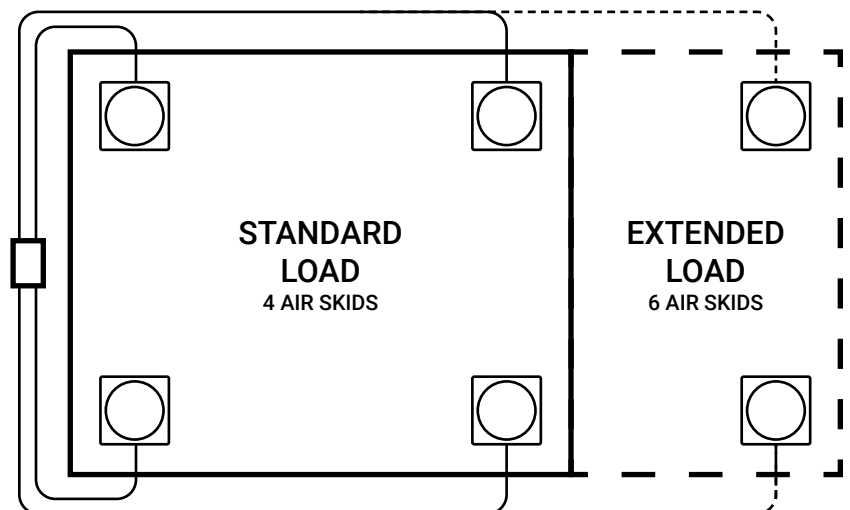



# AIR SKID: RIGGING KIT



POWERED BY  
**COMPRESSED AIR**



STANDARD CAPACITIES  
**75,000 LBS+**



HEIGHT AS LOW AS  
**3 INCHES**



OMNI-DIRECTIONAL  
**MOVEMENT**

The Air Skid Rigging Kit includes everything needed to operate Air Skids, all neatly packed in a heavy duty box. This kit is perfect for quick, easy deployment at job sites and fits comfortably in most pickup truck beds. It features custom inserts for organization and forklift pockets for hassle-free loading and unloading. The kit also includes two spare air casters, allowing for quick replacement in case of damage.

- **Heavy-duty locking box**
- **Everything in one box needed for Air Skid moves**
- **Easily moved from job to job**
- **Space saving storage when not in use**
- **Provides entire Air Skid system, instead of individual skids**



## WHAT'S IN THE BOX?

The Air Skid Rigging Kit includes 6 Air Skids, 2 spare Air Casters, a 6-port Air Skid controller with Deadman pendant, 1 supply hose for the controller, and 6 individual hoses for each Air Skid. All components are safely secured in a heavy-duty locking box.

## STORAGE & TRANSPORTATION MADE EASY

Everything needed for the job and more, the Rigging Kit makes Air Skid storage and transportation easy. The portable kit fits in most pickup truck beds and can be unloaded using its heavy-duty recessed side handles or a forklift.

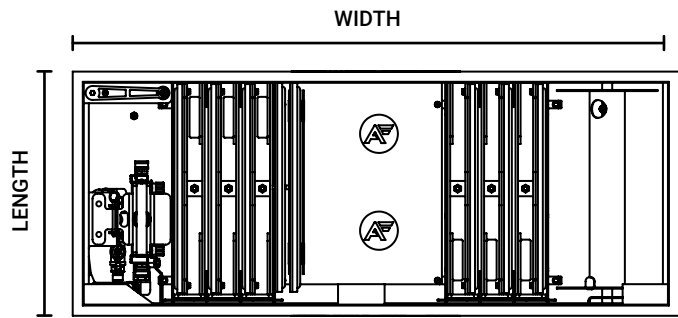

TOP VIEW (WITHOUT LID)

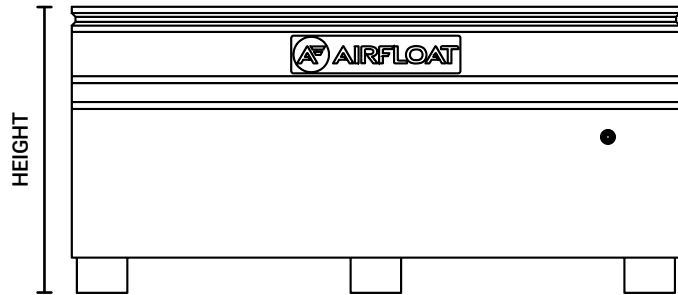

FRONT VIEW

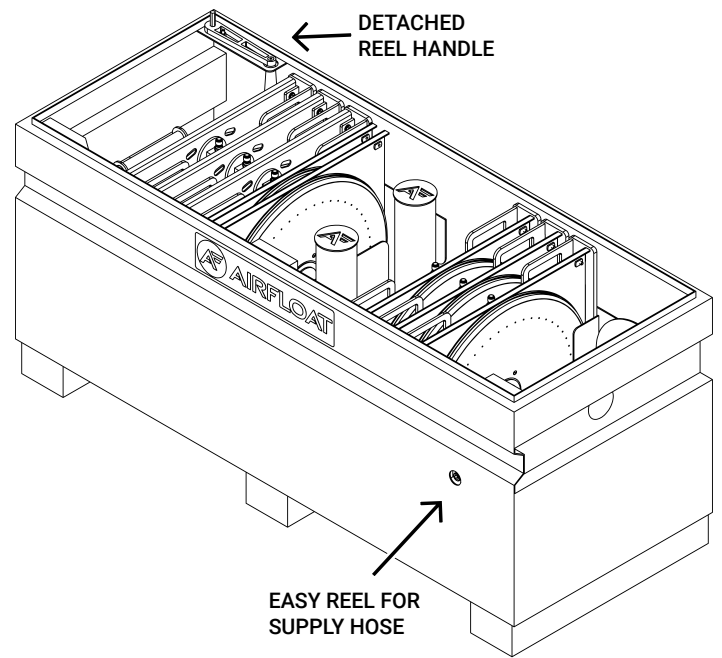

ISOMETRIC VIEW (WITHOUT LID)

SEE PAGES 11-12 FOR AIR SKID SPECIFICATIONS AND DRAWINGS

## AIR SKID RIGGING KIT SPECIFICATIONS

MODELS	SET OF 4 SKIDS			SET OF 6 SKIDS			BOX SIZE L x W x H
	CAPACITY	AIR FLOW	WEIGHT	CAPACITY	AIR FLOW	WEIGHT	
STANDARD							
AF01112 12" CASTER	12,000 lbs 5,443 kg	44 SCFM 1,246 L/m	756 lbs 342 kg	18,000 lbs 8,165 kg	66 SCFM 1,869 L/m	826.5 lbs 374 kg	60 x 24 x 28.25 in 1,524 x 610 x 718 mm
AF01117 17" CASTER	25,000 lbs 11,340 kg	64 SCFM 1,812 L/m	855 lbs 387 kg	37,500 lbs 17,010 kg	96 SCFM 2,718 L/m	975 lbs 442 kg	60 x 24 x 28.25 in 1,524 x 610 x 718 mm
AF01120 20" CASTER	33,000 lbs 14,969 kg	72 SCFM 2,039 L/m	912 lbs 413 kg	49,500 lbs 22,453 kg	108 SCFM 3,058 L/m	1060.5 lbs 481 kg	60 x 24 x 28.25 in 1,524 x 610 x 718 mm
AF01124 24" CASTER	50,000 lbs 22,680 kg	88 SCFM 2,492 L/m	1200 lbs 544 kg	75,000 lbs 34,019 kg	132 SCFM 3,738 L/m	1420 lbs 644 kg	66 x 30 x 36 in 1,676 x 762 x 914 mm

1. Inflated height adds approximately 1/16th in (1.6mm) to 1.875 in (47.6mm), depending on model.

### INCLUDED IN AIR SKID RIGGING KIT

PRODUCT	QUANTITY
AIR SKIDS	4 or 6
AIR SKID CONTROLLER	1
DEADMAN PENDANT	1
32FT SINGLE HOSE	4 or 6
SPARE AIR CASTER	2
85FT SUPPLY HOSE	1





# AIR SKID: LIFT GLIDES



POWERED BY  
**COMPRESSED AIR**



STANDARD CAPACITIES  
**125,000 LBS+**



HEIGHT AS LOW AS  
**5.75 INCHES**



OMNI-DIRECTIONAL  
**MOVEMENT**

Air Skid Lift Glides are mounted onto a load or cart, keeping it slightly elevated off the floor. This provides flexibility for the load to rest on the floor or be moved on wheels. When the load needs to be moved or is too heavy for the wheels, lower the Lift Glides to the floor. This action inflates the Lift Glides and lifts the load and wheels off the ground. Then air bearings are inflated creating a cushion of air, allowing for easy, near-frictionless movement.

- *Fitted to new & existing tooling*
- *Easy maintenance with slide-out trays*
- *Flexibility to use wheeled cart for distance when unloaded, switch to Lift Glides when loaded for precise movement*
- *Distribute the load over a larger area, reducing the risk of floor damage*

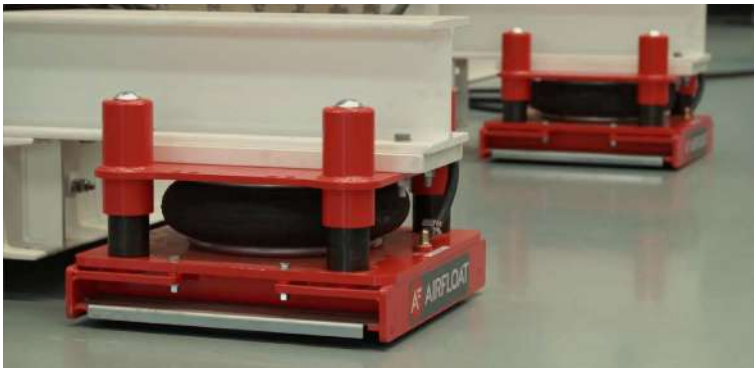

## FITTED TO A LOAD OR FIXTURE

When fitted to a load or fixture, the Lift Glides can remain in the up position, keeping the load safe and secure on the floor. When needed, they lift and inflate for easy movement, then deflate to secure the load again.



## FITTED TO A WHEELED CART

When fitted to a wheeled cart, they allow the cart to roll on its wheels when it's light or unloaded, which is useful when an air supply is unavailable or on rough flooring. When the load is too heavy, the Lift Glides can lift and inflate for easy movement.

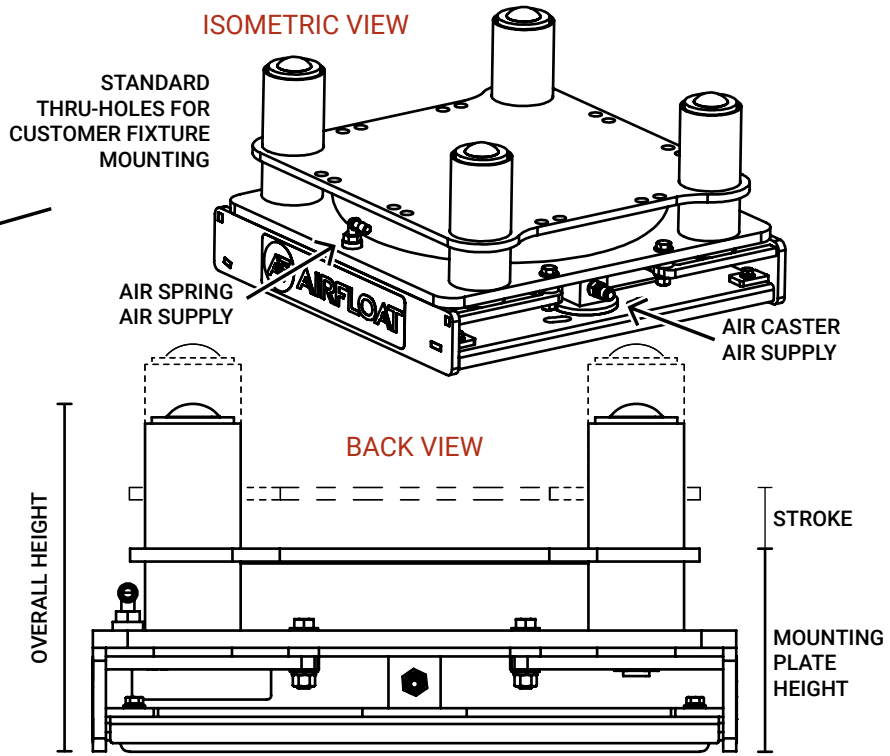
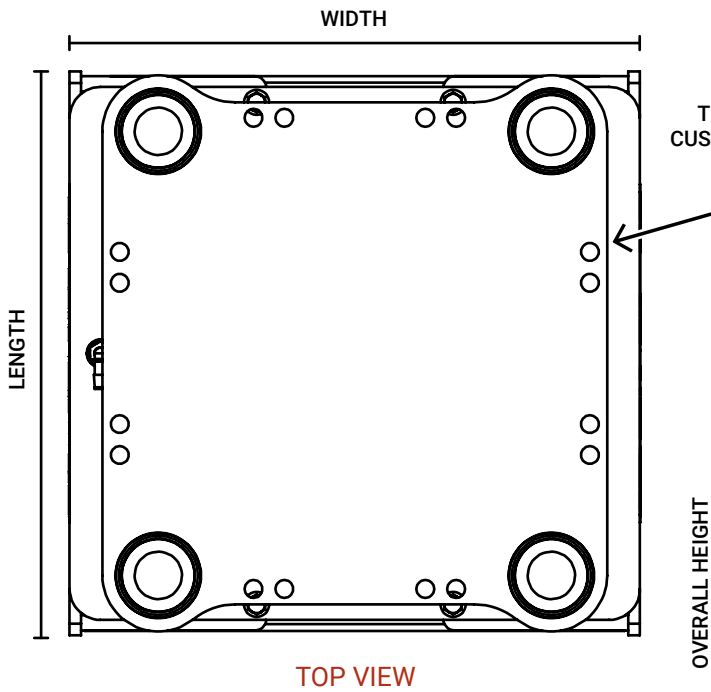

## SET OF 4 AIR SKID LIFT GLIDES SPECIFICATIONS

MODELS	SET OF 4 GLIDES		STROKE	MOUNTING PLATE HEIGHT		SKID SIZE
	CAPACITY	AIR FLOW		DEFLATED <sup>1</sup>	L x W x OVERALL HEIGHT <sup>1</sup>	
STANDARD			LIFT			
AF06012-4 12" CASTER	10,000 lbs 4,536 kg	44 SCFM 1,246 L/m	2.88 in 73 mm	5.75 in 146 mm	15.28 x 14.3 x 9.94 in 388 x 363 x 252 mm	
AF06017-4 17" CASTER	18,000 lbs 8,165 kg	64 SCFM 1,812 L/m	2.88 in 73 mm	5.88 in 149 mm	18.5 x 18.3 x 10.06 in 470 x 465 x 256 mm	
AF06020-4 20" CASTER	32,000 lbs 14,515 kg	72 SCFM 2,039 L/m	2.88 in 73 mm	6 in 152 mm	21.5 x 21.3 x 12.06 in 546 x 541 x 306 mm	
AF06024-4 24" CASTER	48,000 lbs 21,772 kg	88 SCFM 2,492 L/m	2.88 in 73 mm	7.13 in 181 mm	25.75 x 25.3 x 15.06 in 654 x 643 x 383 mm	
AF06030-4 30" CASTER	85,000 lbs 38,555 kg	112 SCFM 3,172 L/m	2.88 in 73 mm	8.63 in 219 mm	31.75 x 31.5 x 15.9 in 806 x 800 x 404 mm	
AF06036-4 36" CASTER	125,000 lbs 56,699 kg	140 SCFM 3,964 L/m	2.375 in 60 mm	9.13 in 232 mm	37.75 x 37.5 x 15.9 in 959 x 953 x 404 mm	

1. Deflated height, inflated height adds approximately 1/16th in (1.6mm) to 1.5 in (38mm), depending on model.

### INCLUDED WITH LIFT GLIDE SET

PRODUCT	QUANTITY
AIR SKIDS LIFT GLIDE	4
LIFT GLIDE CONTROLLER	1
100FT HOSE & CLAMPS	1
SPARE AIR CASTER	1
EXTRA 100FT HOSE	OPTIONAL
CONTROLLER WITH DEADMAN	OPTIONAL

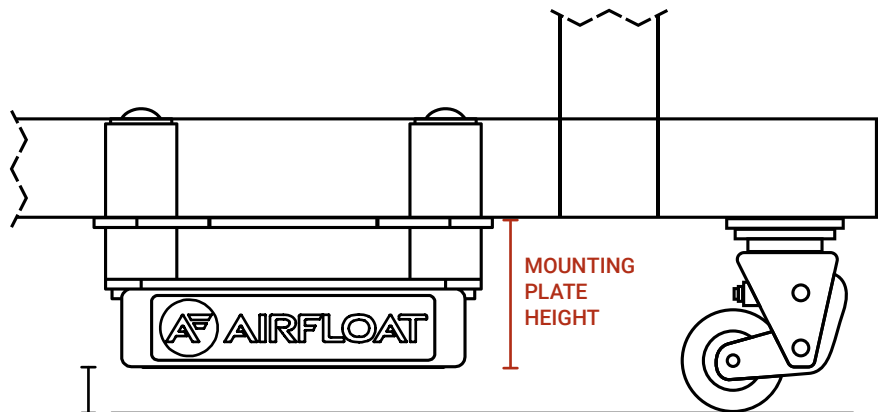

INSTALL WITH 1/2" MINIMUM CLEARANCE WITH FLOOR



# AIRFLOAT PLANKS



POWERED BY  
**COMPRESSED AIR**



STANDARD CAPACITIES  
**306,000 LBS+**



HEIGHT AS LOW AS  
**2.5 INCHES**



OMNI-DIRECTIONAL  
**MOVEMENT**

Air Planks are long, low-profile rectangular platforms placed under the load. When the Air Casters are inflated, they create a cushion of air that lifts the load, allowing for smooth, near-frictionless movement. Depending on the load's capacity and size, planks are used in sets of two or three to support and distribute the load evenly. They are available in lightweight aluminum or heavy-duty steel, with customizable lengths.

- *Lightweight aluminum or heavy-duty steel*
- *Add Planks for greater load flexibility*
- *Structural platform for load support*
- *Easy maintenance with slide-out trays*
- *Distribute the load over a larger area, reducing the risk of floor damage*
- *UHMW rest pads protect floor when deflated*



## LIGHTWEIGHT ALUMINUM PLANKS

Constructed from extruded aluminum, our Aluminum Planks are a lightweight alternative to Steel Planks. Both are stackable for efficient storage, with the Aluminum Planks offering greater portability, as they can be carried by two people. (60 - 200 lbs)



## HEAVY-DUTY STEEL PLANKS

Constructed from structural steel, these heavy-duty Steel Planks are highly durable and provide sturdy support for even the heaviest of loads. They are stackable for efficient storage and include fork pockets and a retractable guide wheel.

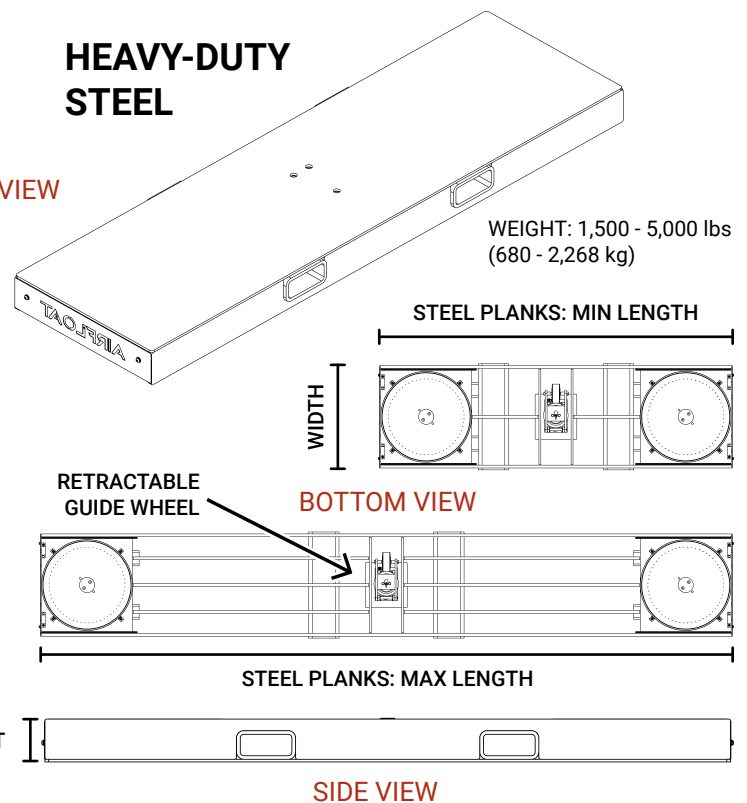
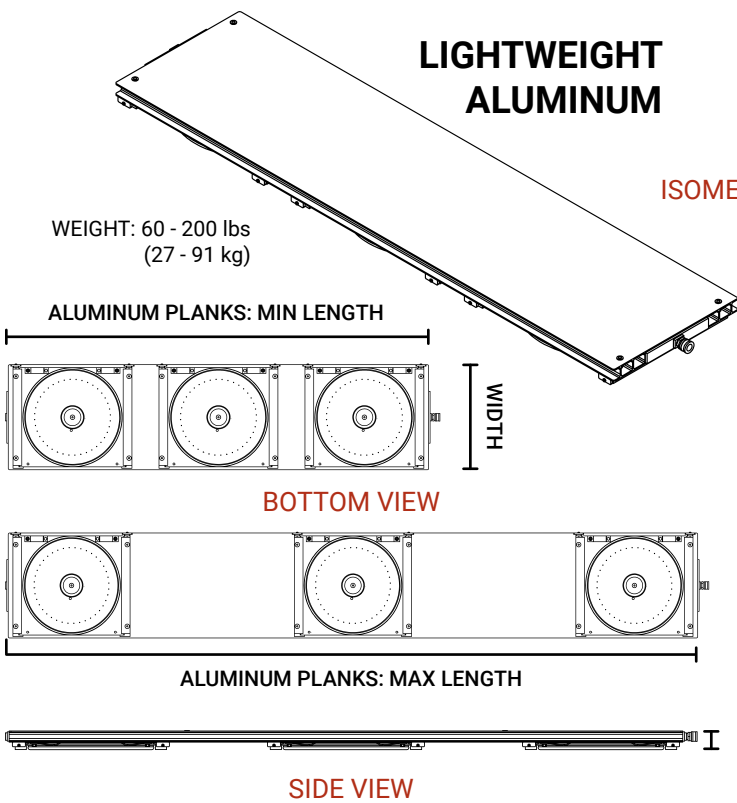

## SET OF 2 & 3 AIR PLANKS SPECIFICATIONS

	MODELS	SET OF 2 PLANKS		SET OF 3 PLANKS		PLANK SIZES		
		STANDARD	CAPACITY	AIR FLOW	CAPACITY	AIR FLOW	LENGTH	WIDTH
ALUMINUM PLANKS	AF04012 12" CASTER	18,000 lbs 8,165 kg	66 SCFM 1,869 L/m	27,000 lbs 12,247 kg	99 SCFM 2,803 L/m	60 - 144 in 1,524 - 3,658 mm	13 in 330 mm	2.5 in 64 mm
	AF04017 17" CASTER	37,500 lbs 17,010 kg	96 SCFM 2,718 L/m	56,250 lbs 25,515 kg	144 SCFM 4,078 L/m	66 - 144 in 1,524 - 3,658 mm	18 in 457 mm	2.5 in 64 mm
	AF04020 20" CASTER	49,500 lbs 22,453 kg	108 SCFM 3,058 L/m	74,250 lbs 33,679 kg	162 SCFM 4,587 L/m	72 - 144 in 1,829 - 3,658 mm	21 in 533 mm	2.5 in 64 mm
	AF04024 24" CASTER	75,000 lbs 34,019 kg	164 SCFM 4,644 L/m	112,500 lbs 51,029 kg	246 SCFM 6,966 L/m	84 - 144 in 2,134 - 3,658 mm	24.75 in 629 mm	2.5 in 64 mm
STEEL PLANKS	AF04124 24" CASTER	47,000 lbs 21,319 kg	110 SCFM 3,115 L/m	70,500 lbs 31,978 kg	165 SCFM 4,672 L/m	96 - 156 in 2,438 - 3,962 mm	27 in 686 mm	6 in 152 mm
	AF04130 30" CASTER	81,500 lbs 36,968 kg	142 SCFM 4,021 L/m	122,250 lbs 55,452 kg	213 SCFM 6,031 L/m	108 - 156 in 2,743 - 3,962 mm	33 in 838 mm	6 in 152 mm
	AF04136 36" CASTER	121,000 lbs 54,885 kg	172 SCFM 4,870 L/m	181,500 lbs 82,327 kg	258 SCFM 7,306 L/m	120 - 168 in 3,048 - 4,267 mm	39 in 991 mm	6 in 152 mm
	AF04148 48" CASTER	204,000 lbs 92,533 kg	236 SCFM 6,683 L/m	306,000 lbs 138,799 kg	354 SCFM 10,024 L/m	144 - 180 in 3,658 - 4,572 mm	51 in 1,295 mm	6.5 in 165 mm

1. Deflated height, inflated height adds approximately 1/16th in (1.6mm) to 1.875 in (47.6mm), depending on model.

### INCLUDED WITH AIR PLANK SET

PRODUCT	QUANTITY	PRODUCT	QUANTITY
AIR PLANKS	2 or 3	32FT SINGLE HOSE	2 or 3
AIR PLANK CONTROLLER	1	SPARE AIR CASTER	1
DEADMAN PENDANT	1		



# AIRFLOAT UTILITY PLATFORM



 **POWERED BY  
COMPRESSED AIR**

 **CAPACITIES UP TO  
12,000 LBS**

 **HEIGHT AS LOW AS  
3 INCHES**

 **CUSTOMIZABLE  
PLATFORM**

Utility Platforms are customizable, low-profile platforms operated by a single operator. These walk-behind platforms use Air Casters that, when inflated, create a cushion of air, lifting the load and allowing for smooth, near-frictionless movement. Utility Platforms provide structural support and can be tailored to meet specific load requirements. They can also be paired with lift tables for height variations and equipped with chocks for securing rolls.

- **Structural platform for load support**
- **Optional chocks for securing rolls**
- **Retractable guide wheel for straight line movement**
- **UHMW rest pads protect floor when deflated**
- **Distribute the load over a larger area, reducing the risk of floor damage**



## INTEGRATE ERGONOMIC EQUIPMENT

Utility Platforms can be combined with other ergonomic equipment, such as lift tables. Lift tables can be adjusted to the optimal height for loading and unloading, while the Utility Platform makes it easy to move and position the load.



## MOVE ROLLS WITH UTILITY PLATFORMS

Utility Platforms offer excellent structural support, making them ideal for rolls, with chocks for secure placement and an extended handle to accommodate larger rolls. Additionally, they can be paired with lift tables for added versatility.

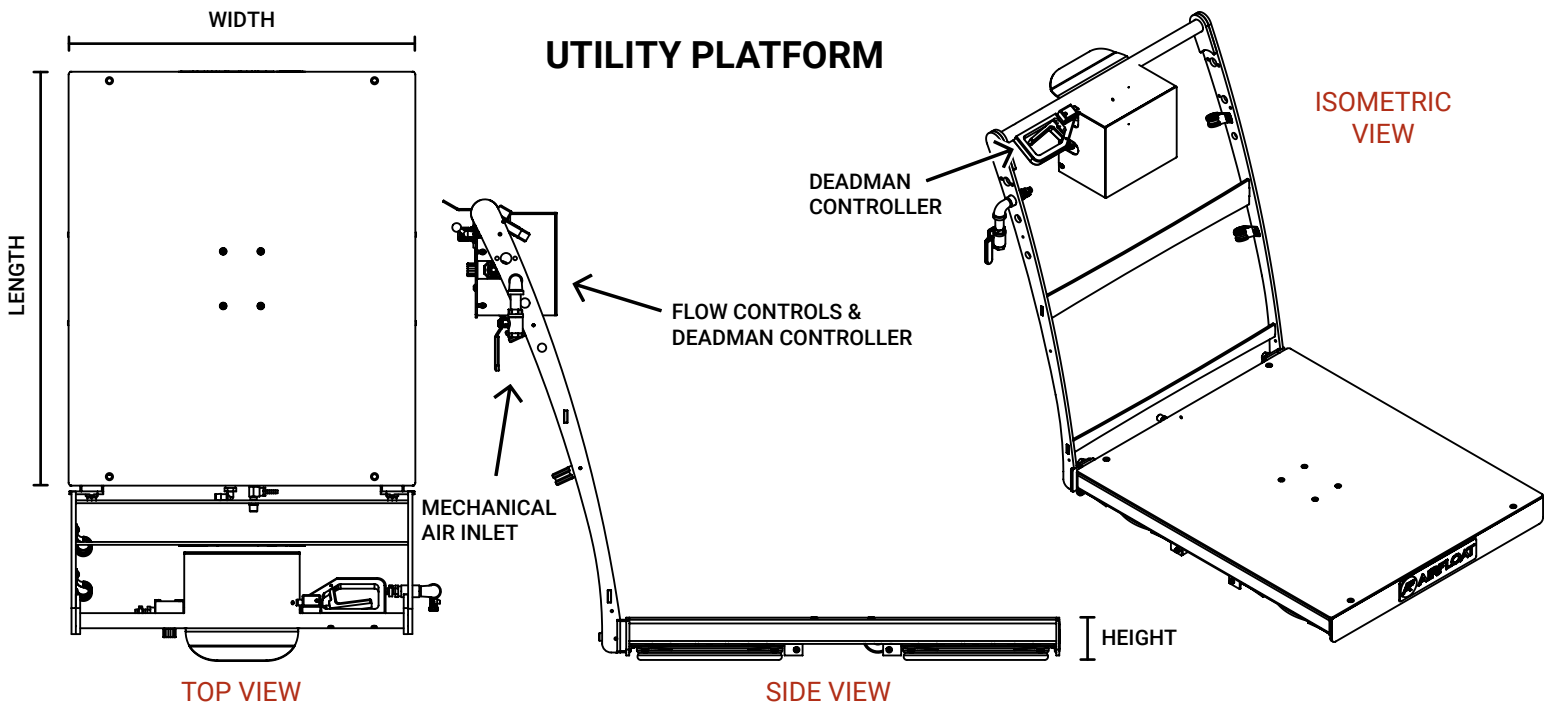

## UTILITY PLATFORM SPECIFICATIONS

MODELS	CAPACITY	AIR FLOW	LENGTH	WIDTH	HEIGHT
STANDARD	TOTAL	AIR FLOW	MIN - MAX <sup>1</sup>		DEFLATED <sup>2</sup>
AF020-30 12" CASTER	8,000 lbs 3,629 kg	44 SCFM 1,246 L/m	30 - 60 in 762 - 1,524 mm	30 in 762 mm	3 in 76 mm
AF020-36 12" CASTER	8,000 lbs 3,629 kg	44 SCFM 1,246 L/m	36 - 72 in 914 - 1,829 mm	36 in 914 mm	3 in 76 mm
AF020-42 17" CASTER	12,000 lbs 5,443 kg	64 SCFM 1,812 L/m	42 - 84 in 1,067 - 2,134 mm	42 in 1,067 mm	3 in 76 mm
AF020-48 17" CASTER	12,000 lbs 5,443 kg	64 SCFM 1,812 L/m	48 - 96 in 1,219 - 2,438 mm	48 in 1,219 mm	3 in 76 mm
AF020-60 17" CASTER	12,000 lbs 5,443 kg	64 SCFM 1,812 L/m	60 - 120 in 1,524 - 3,048 mm	60 in 1,524 mm	3 in 76 mm

CUSTOM PLATFORM SIZES, CAPACITIES, AND CONFIGURATIONS AVAILABLE

1. Standard lengths available in 6" increments. 2. Inflated height adds approximately 1/16th in (1.6mm) to 1 in (25mm), depending on model.

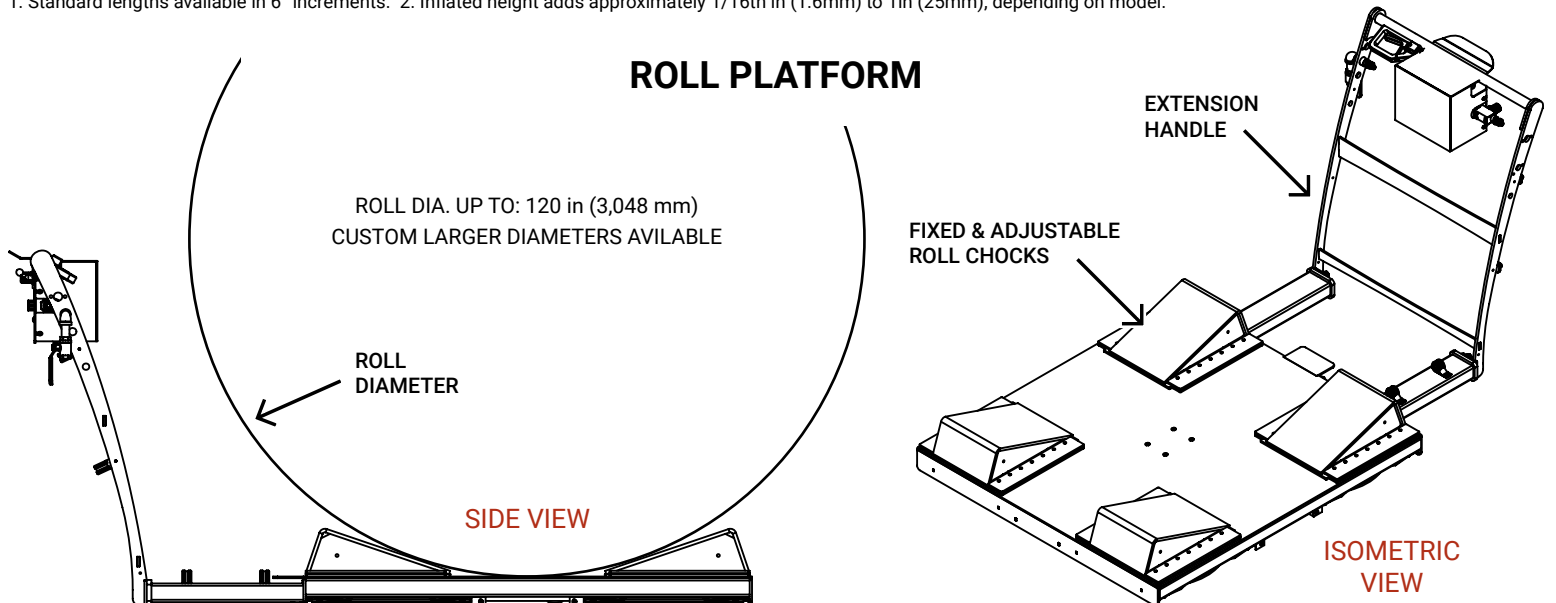



# AIRFLOAT PLATFORM

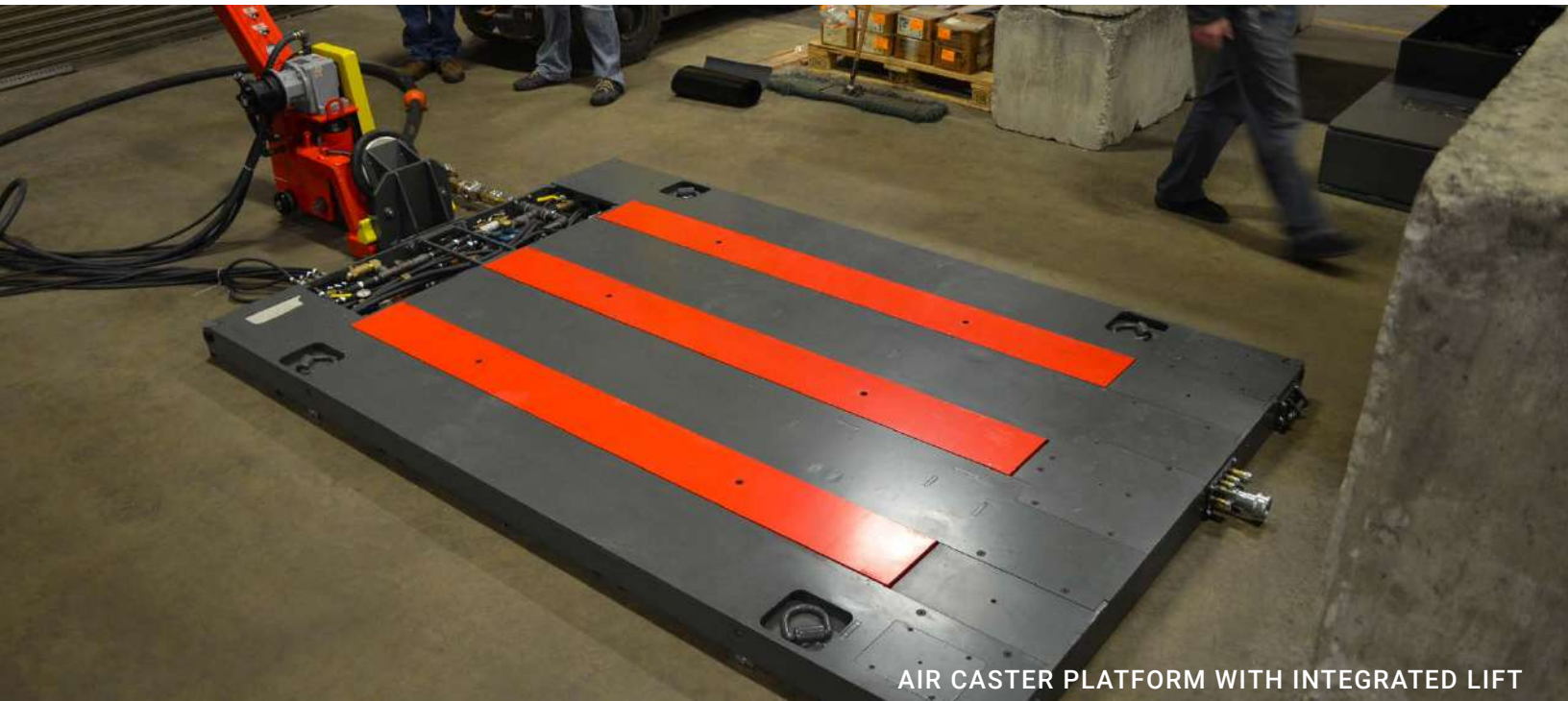

AIR CASTER PLATFORM WITH INTEGRATED LIFT



POWERED BY  
**COMPRESSED AIR**



STANDARD CAPACITIES  
**120,000 LBS+**



HEIGHT AS LOW AS  
**5 INCHES**



CUSTOMIZABLE  
**PLATFORM**

Air Platforms are a two-part system consisting of a load-carrying platform and a push-pull tugger, allowing a single operator to move heavy loads with ease. The platform provides structural support and can be customized to meet specific load requirements. Loads can be placed directly on the platform or, with a secondary lift, the Air Platform can slide under the load or pallet, lifting it off the floor for transport.

- **Walk-behind pneumatic push-pull tugger**
- **Structural platform for load support**
- **Retractable guide wheel offered for straight line movement**
- **Easy maintenance with slide-out trays**
- **Optional lift deck for pallet raising**



## PNEUMATIC PUSH-PULL TUGGER

The pneumatic tugger hitches onto the platform and, using quick connects, supplies air to the platform, with all controls located on the tugger. It can push and pull loads, offering variable control for precise movements.



## EFFICIENT LOADING WITH INTEGRATED LIFT

Placing the load directly onto the platform is possible, but a secondary lift is often used. Loads are placed on large pallets, allowing the Air Platform to be driven underneath, lifted off the floor, and moved with the tugger.

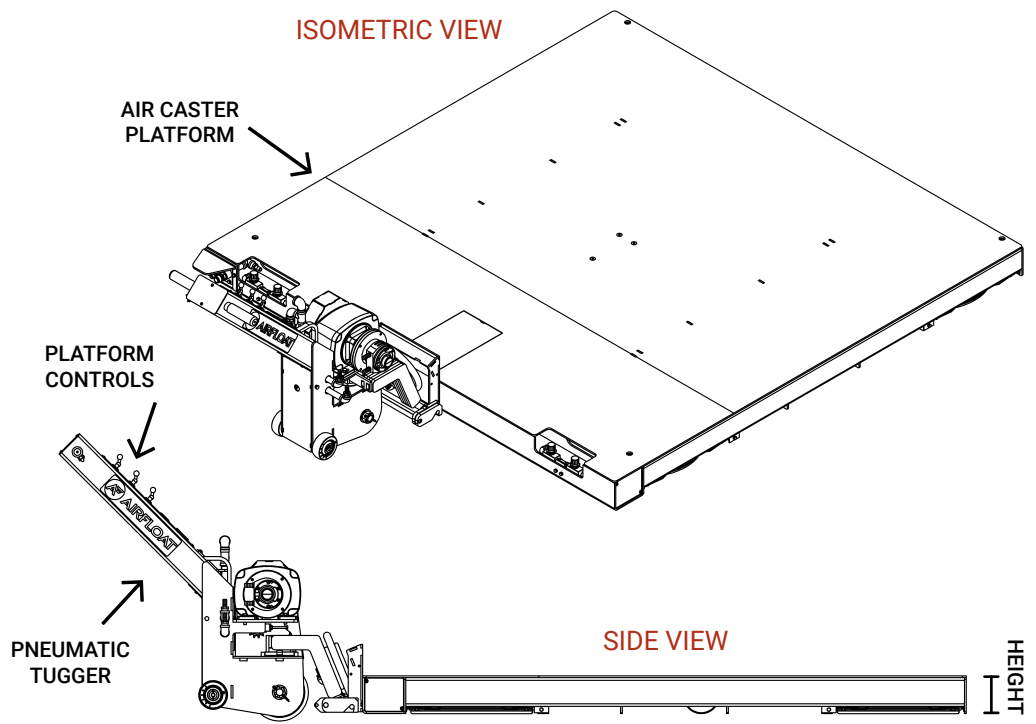
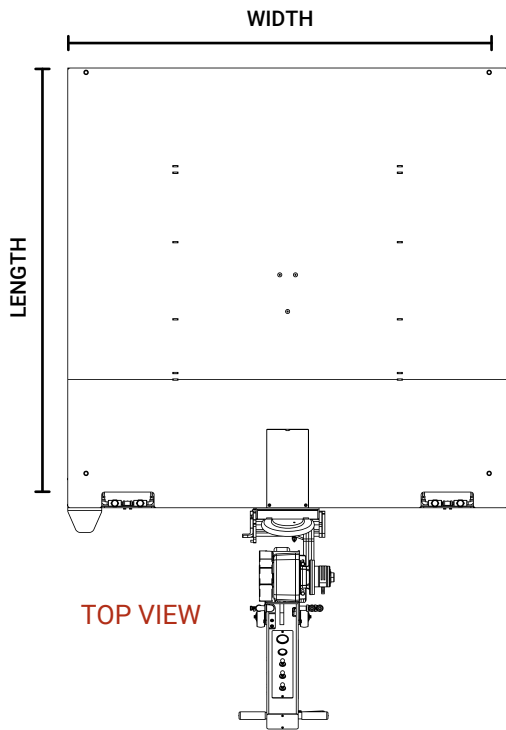

## AIR CASTER PLATFORM SPECIFICATIONS

MODELS	CAPACITY	AIR FLOW	LENGTH	WIDTH	HEIGHT
STANDARD	TOTAL	AIR FLOW	MIN - MAX <sup>1</sup>	MIN - MAX <sup>1</sup>	DEFLATED <sup>2</sup>
AF030 17" CASTER	22,000 lbs 9,979 kg	48 SCFM 1,359 L/m	48 - 144 in 1,219 - 3,658 mm	48 - 84 in 1,219 - 2,134 mm	5 in 127 mm
AF031 24" CASTER	45,000 lbs 20,412 kg	66 SCFM 1,869 L/m	60 - 144 in 1,524 - 3,658 mm	60 - 96 in 1,524 - 2,438 mm	5 in 127 mm
AF032 30" CASTER	80,000 lbs 36,287 kg	85 SCFM 2,407 L/m	76 - 156 in 1,930 - 3,962 mm	76 - 108 in 1,930 - 2,743 mm	7 in 178 mm
AF033 36" CASTER	120,000 lbs 54,431 kg	100 SCFM 2,832 L/m	86 - 210 in 2,184 - 5,334 mm	86 - 132 in 2,184 - 3,353 mm	7 in 178 mm

CUSTOM PLATFORM SIZES, CAPACITIES, AND CONFIGURATIONS AVAILABLE

1. Standard lengths available in 6" increments. 2. Inflated height adds approximately 1/16th in (1.6mm) to 1.5 in (38mm), depending on model.

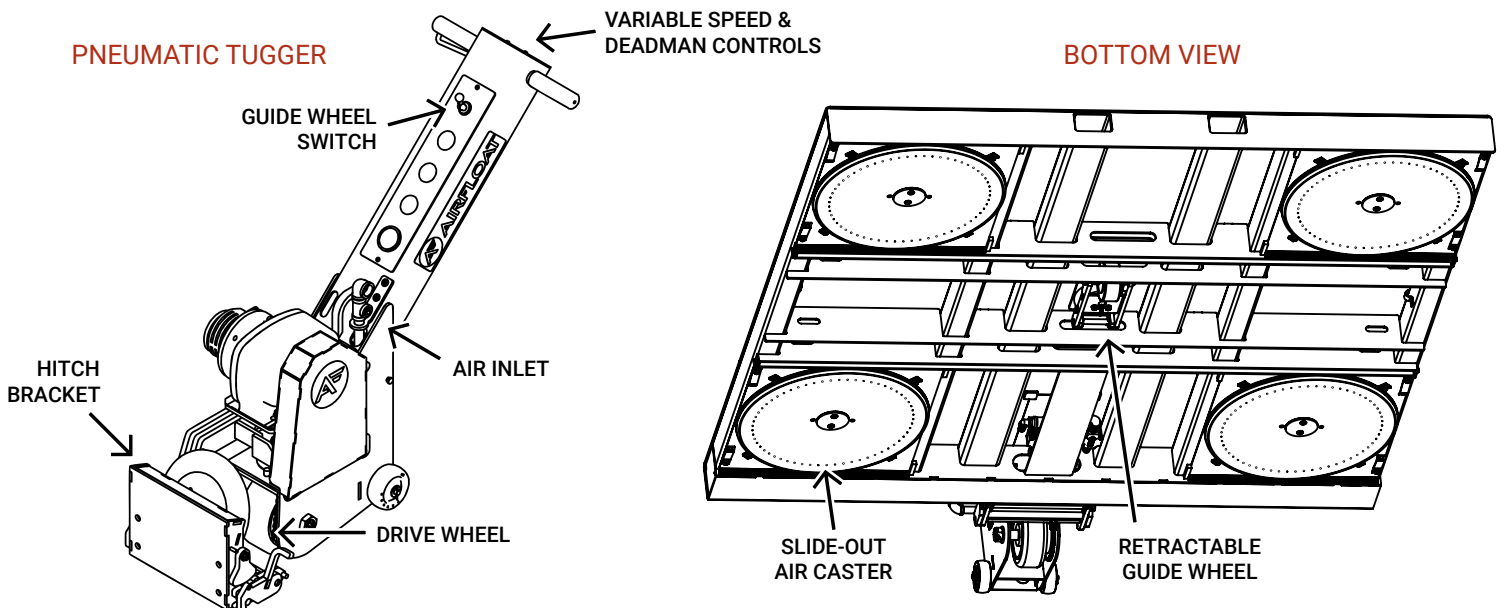



# AIRFLOAT TRANSPORTER



POWERED BY  
**COMPRESSED AIR**



STANDARD CAPACITIES  
**200,000 LBS+**



HEIGHT AS LOW AS  
**10 INCHES**



CUSTOMIZABLE  
**PLATFORM**

Air Transporters are an all-in-one system consisting of a load-carrying platform with an integrated drive system. Unlike the Air Platform, which requires a tugger, the Air Transporter uses a tethered hand pendant. The platform provides structural support to the load and can be customized to specific load requirements. The load can be placed directly on the platform or secondary lift, can slide under the load or pallet, lifting it off the floor for transport.

- *Integrated drive with pendant controller*
- *Structural platform for load support*
- *Easy maintenance with slide-out trays*
- *Distribute the load over a larger area, reducing the risk of floor damage*



## INTEGRATED DRIVES AND HAND PENDANT

Depending on the setup, one or more pneumatic drives are integrated into the platform and controlled by a tethered hand pendant, providing the operator with greater flexibility in positioning. If included, it also controls the secondary lift.



## EFFICIENT LOADING WITH SECONDARY LIFT

Placing the load directly onto the platform is possible, but a secondary lift is often included. Loads are placed on large pallets, allowing the Air Platform to be driven underneath, lifted off the floor, and moved with the controller.

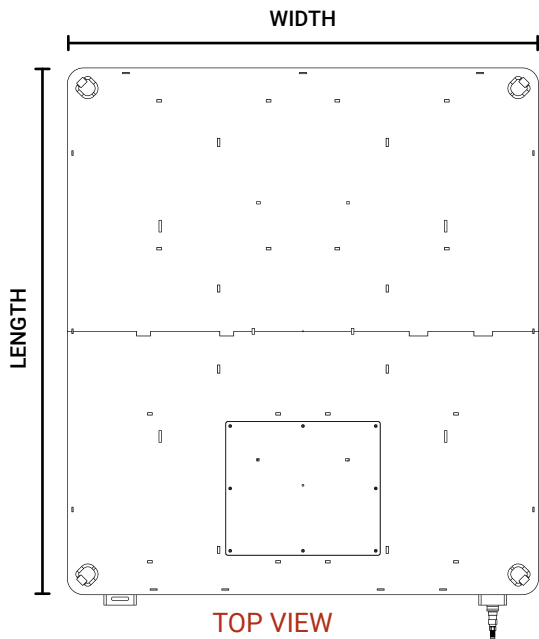

TOP VIEW

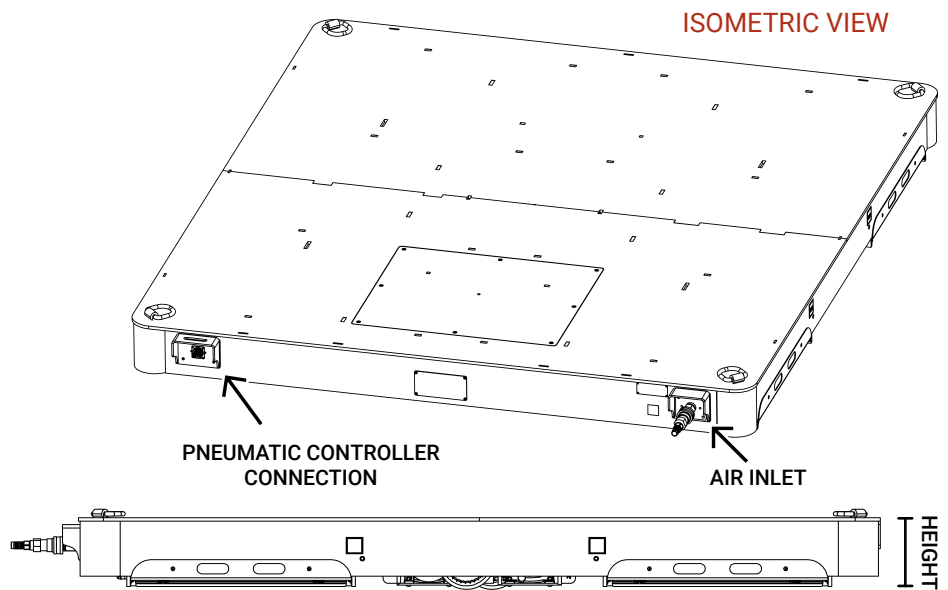

SIDE VIEW

## AIR CASTER TRANSPORTER SPECIFICATIONS

MODELS	CAPACITY	AIR FLOW	LENGTH	WIDTH	HEIGHT
STANDARD	TOTAL	AIR FLOW	MIN - MAX <sup>1</sup>	MIN - MAX <sup>1</sup>	DEFLATED <sup>2</sup>
AF070 24" CASTER	45,000 lbs 20,412 kg	66 SCFM 1,869 L/m	96 - 196 in 2,438 - 4,978 mm	96 - 144 in 2,438 - 3,658 mm	10 in 254 mm
AF071 30" CASTER	80,000 lbs 36,287 kg	85 SCFM 2,407 L/m	96 - 196 in 2,438 - 4,978 mm	96 - 144 in 2,438 - 3,658 mm	10 in 254 mm
AF072 36" CASTER	120,000 lbs 54,431 kg	100 SCFM 2,832 L/m	144 - 196 in 3,658 - 4,978 mm	120 - 196 in 3,048 - 4,978 mm	10 in 254 mm
AF073 48" CASTER	200,000 lbs 90,718 kg	140 SCFM 3,964 L/m	144 - 196 in 3,658 - 4,978 mm	144 - 196 in 3,658 - 4,978 mm	10 in 254 mm

CUSTOM PLATFORM SIZES, CAPACITIES, AND CONFIGURATIONS AVAILABLE

1. Standard lengths available in 6" increments. 2. Inflated height adds approximately 0.6875 in (17.5mm) to 1.875 in (47.6mm), depending on model.

PNEUMATIC TUGGER

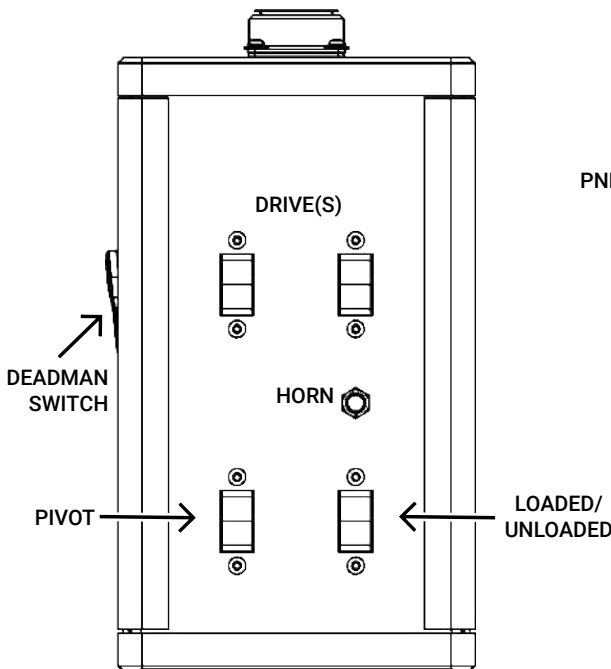

BOTTOM VIEW

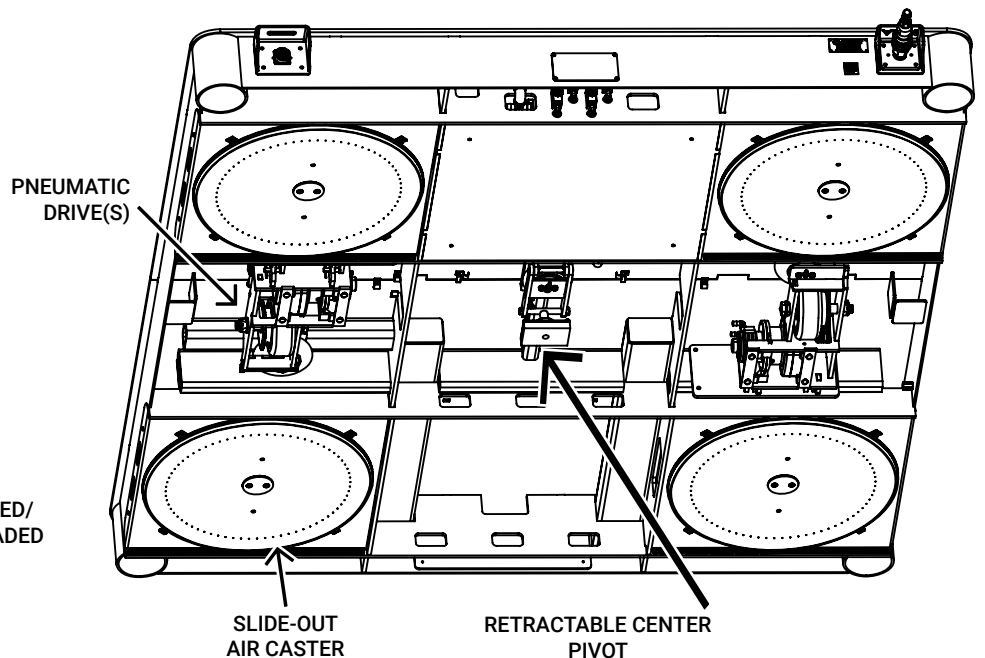



# AIRFLOAT ROLL MOVER



POWERED BY  
**COMPRESSED AIR**



STANDARD CAPACITIES  
**12,000 LBS**



CUSTOMIZABLE  
**FORKS**



OMNI-DIRECTIONAL  
**MOVEMENT**

Roll Movers are U-shaped platforms designed to lift and transport heavy rolls. They slide under the roll from both sides, cradling it securely. A secondary lift raises the roll directly from the floor, allowing it to be moved. The roll is lifted by Air Casters that, when inflated, create a cushion of air for smooth, near-frictionless movement. Available in both fixed and adjustable models, they accommodate a variety of roll sizes.

- *Roll diameters up to 96 inches*
- *Quickly lift roll right off the floor*
- *Fixed and adjustable roll options*
- *Easy maintenance with slide-out trays*
- *Distribute the load over a larger area, reducing the risk of floor damage*



## **FIXED AIR CASTER ROLL MOVER**

The Fixed Air Caster Roll Mover has a “fixed” design meaning the cradle remains stationary without adjustable positioning or rotation, ensuring even the heaviest rolls are securely moved and positioned.



## **ADJUSTABLE AIR CASTER ROLL MOVER**

The Adjustable Air Caster Roll Mover is designed for flexible handling, featuring a cradle that can be tilted, rotated, or adjusted to move rolls of varying sizes for roll positioning and transport.

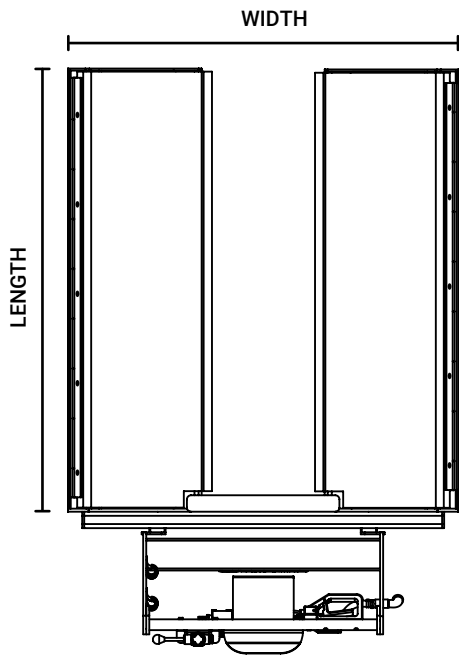

TOP VIEW

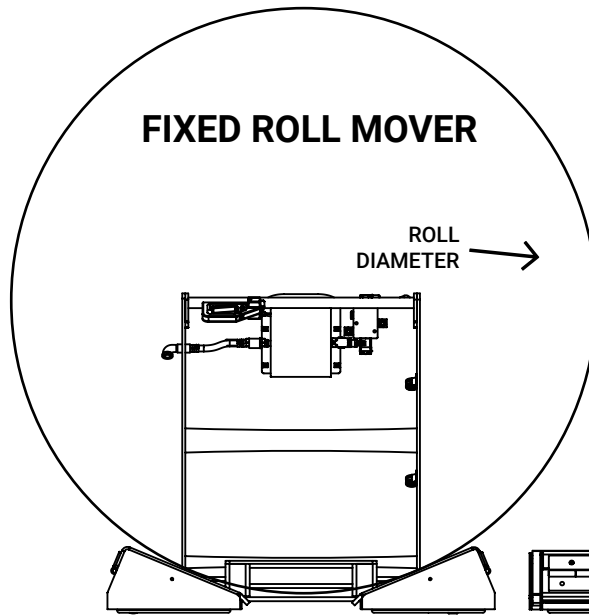

FRONT VIEW

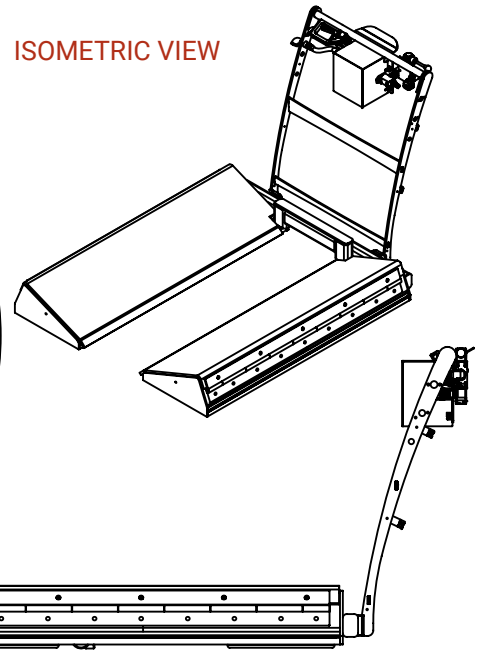

ISOMETRIC VIEW

## AIR ROLL MOVER SPECIFICATIONS

MODELS	CAPACITY	FIXED CRADLE		ADJ. CRADLE		CRADLE SIZE		STROKE
		DIAMETER	AIR FLOW	DIAMETER	AIR FLOW	LENGTH	WIDTH	
STANDARD	TOTAL							LIFT <sup>1</sup>
AF08X-3642 10" CASTER	5,000 lbs 2,268 kg	36 in 914 mm	48 SCFM 1,359 L/m	24 - 36 in 610 - 914 mm	80 SCFM 2,265 L/m	36 in 914 mm	36 in 914 mm	1 in 25 mm
AF08X-4854 12" CASTER	5,000 lbs 2,268 kg	48 in 1,219 mm	54 SCFM 1,529 L/m	36 - 48 in 914 - 1,219 mm	100 SCFM 2,832 L/m	48 in 1,219 mm	48 in 1,219 mm	1 in 25 mm
AF08X-6054 12" CASTER	5,000 lbs 2,268 kg	60 in 1,524 mm	54 SCFM 1,529 L/m	48 - 60 in 1,219 - 1,524 mm	100 SCFM 2,832 L/m	48 in 1,219 mm	48 in 1,219 mm	1.5 in 38 mm
AF08X-7272 14" CASTER	5,000 lbs 2,268 kg	72 in 1,829 mm	62 SCFM 1,756 L/m	60 - 72 in 1,524 - 1,829 mm	120 SCFM 3,398 L/m	60 in 1,524 mm	60 in 1,524 mm	1.5 in 38 mm
AF08X-8472 14" CASTER	5,000 lbs 2,268 kg	84 in 2,134 mm	62 SCFM 1,756 L/m	72 - 84 in 1,829 - 2,134 mm	120 SCFM 3,398 L/m	60 in 1,524 mm	60 in 1,524 mm	2 in 51 mm
AF08X-9696 14" CASTER	5,000 lbs 2,268 kg	96 in 2,438 mm	62 SCFM 1,756 L/m	84 - 96 in 2,134 - 2,438 mm	120 SCFM 3,398 L/m	72 in 1,829 mm	72 in 1,829 mm	2 in 51 mm

CUSTOM PLATFORM SIZES, CAPACITIES, AND CONFIGURATIONS AVAILABLE

1. Standard lengths available in 6" increments. 2. Inflated height adds approximately 0.6875 in (17.5mm) to 1.875 in (47.6mm), depending on model.

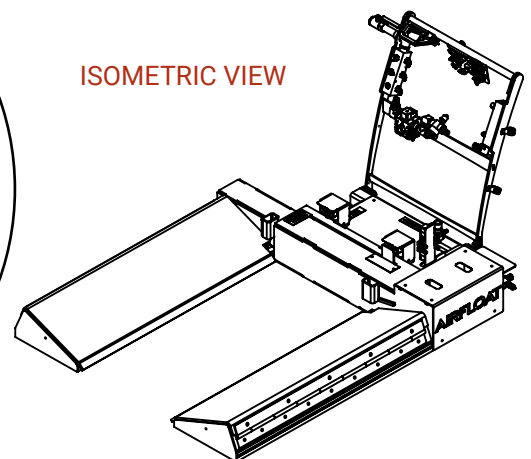
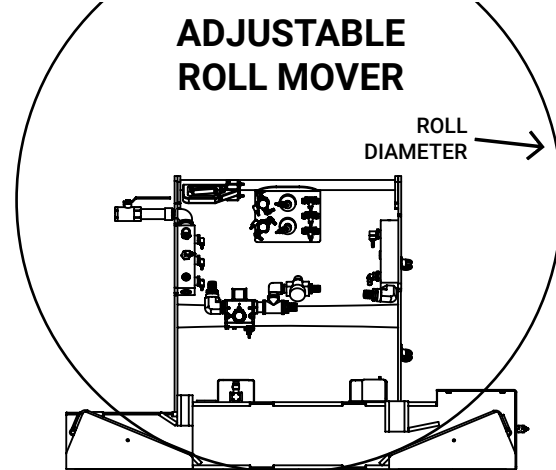
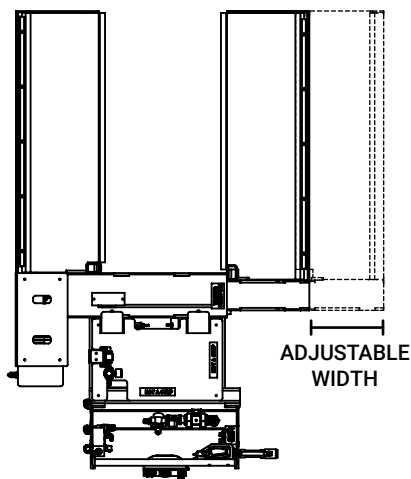

ISOMETRIC VIEW