

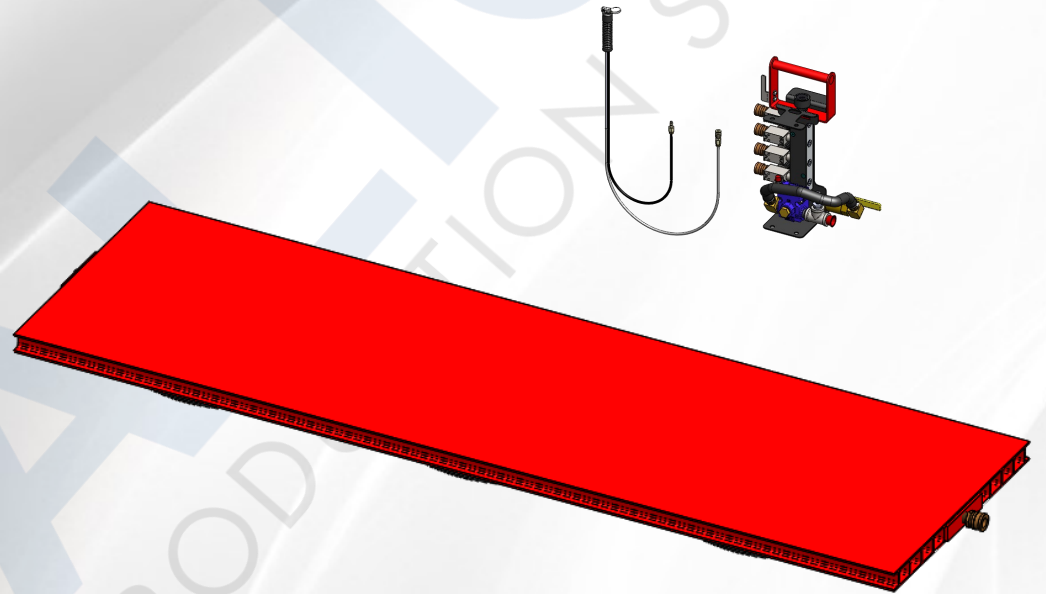

AF040XX-XXX OPERATING MANUAL

AIR BEARING PLANK SYSTEM



ADDRESS

2230 Brush College Road

Decatur, IL 62526

Phone: 217-423-6001

Fax: 217-422-1049

E-mail: sales@alignprod.com

www.alignproductionsystems.com

TABLE OF CONTENTS

1. Introduction and Warranty	3
1.1 Introduction	3
1.1.1 Identification	3
1.1.2 Initial Inspection	3
1.1.3 Important Precautions	3
1.2 Limited Warranty	4
2. Description of Equipment and Specifications	5
2.1 Description of Equipment	5
2.2 Equipment Specifications	5
3. Setup Instructions	5-6
3.1 Positioning the Planks/Workpiece	5-6
4. Operating Information	6
4.1 Operational Controls	6
5. Service and Maintenance	7
5.1 Maintenance Schedule	7
5.2 Maintenance Help	7
5.2.1 Air Bearing Replacement	7
6. Troubleshooting	8
7. Spare Parts	9

1. INTRODUCTION AND WARRANTY

1.1 INTRODUCTION

Please carefully read and understand the information provided in this manual before installing, operating, or servicing this equipment. Failure to do so can result in equipment damage and/or serious personal injury. For any questions, please contact customer service at 217-423-6001.

1.1.1 IDENTIFICATION

When requesting information for ordering parts or service on this equipment, please refer to the model and serial number. The equipment is supplied with a nameplate that contains this information.

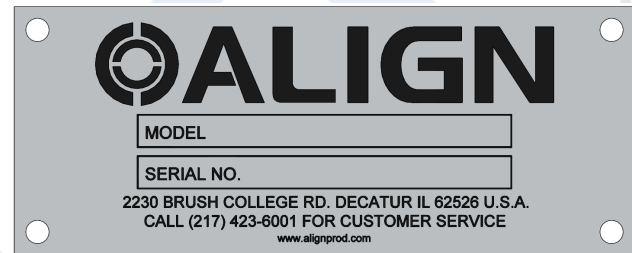

Model Number:

AF04012-XXXX – 12” Air Bearing Planks
 AF04017-XXXX– 17” Air Bearing Planks
 AF04020-XXXX– 20” Air Bearing Planks
 AF04024-XXXX– 24” Air Bearing Planks

1.1.2 INITIAL INSPECTION

Upon receipt, inspect the equipment for possible damage that may have occurred during shipment or unpacking. Please contact Align Production Systems if there is any damage to the unit that may hinder the operation.

1.1.3 IMPORTANT PRECAUTIONS

Read the following safety precautions before operating or servicing your Align Production Systems Industrial equipment:

- **BEFORE any service or maintenance is performed to this equipment** follow correct lockout/tagout procedures.
- Prevent personnel from leaning on equipment and containers or placing their arms, hands, legs or any bodily member in pinch-point areas throughout the system.
- Instruct personnel on the proper placement of product on the equipment. Failure to place containers or loads in the engineered locations may hinder the operation of the equipment and/or cause structural damage.
- Place stop barriers at the fork truck loading area(s) to prevent damage to the equipment.
- Never operate the equipment without the provided covers and guards properly installed.
- Never walk or climb into or onto the equipment while it is in motion.
- Never restore power or air pressure to the control system without first clearing the equipment of personnel, tools or other obstructions.

1.2 LIMITED WARRANTY



LIMITED WARRANTY

Align Production Systems (APS) warrants all of its products to be free of defects in material and workmanship for a period of one (1) year from date of shipment to the original purchaser or 2,000 operating hours, whichever comes first, provided purchaser gives APS prompt notice of the alleged defect(s) and, if requested by APS, returns the defective items, freight prepaid (F.O.B. APS's plant in Decatur, Illinois).

THE WARRANTIES SET FORTH HEREIN ARE IN LIEU OF ALL OTHER WARRANTIES, WHETHER EXPRESS OR IMPLIED, INCLUDING, WITHOUT LIMITATION, FITNESS FOR A PARTICULAR PURPOSE AND MERCHANTABILITY, ALL OF WHICH ARE EXPRESSLY DISCLAIMED.

For any claim under warranty, APS may elect to repair or replace the defective component or components. All claims for warranty must be accompanied by a Return Goods Authorization number, which may be obtained from APS. This warranty does not cover, and APS is not responsible for, any labor or other expense for inspections, removal or reinstallation of components or products.

This warranty does not cover, among other things, damages resulting from foreign matter or water, negligence, accident, unreasonable use, abuse or misuse, alterations not authorized by APS, failure to provide reasonable and necessary maintenance or failure to follow operating instructions or load limits.

IN ADDITION, IN NO EVENT SHALL APS BE LIABLE FOR ANY SPECIAL, INDIRECT, INCIDENTAL, CONSEQUENTIAL OR CONTINGENT DAMAGES, WHETHER OR NOT IT HAS BEEN ADVISED OF THE POSSIBILITY OF SUCH DAMAGES.

APS makes no representation that the product complies with local, state or federal safety/product standards codes. If the product fails to comply in any way with those codes, it shall not be considered a defect in materials or workmanship, and APS shall not be liable for any damages resulting from noncompliance. This limited warranty is provided to the original purchaser (meaning the original end user) and is nontransferable. This limited warranty constitutes the complete and final agreement regarding APS warranty obligations for the product.

2. DESCRIPTION OF EQUIPMENT

2.1 DESCRIPTION OF EQUIPMENT

Each plank is equipped with three slide out air bearing trays . The individual planks are connected with quick-disconnect air lines and can be configured in any orientation to accommodate different size/weight loads. Units can be controlled an optional single handheld pendant with deadman for safety operation.

2.2 EQUIPMENT SPECIFICATIONS

Model Number	Capacity Per Plank (lbs.)	Capacity 2 Planks (lbs.)	Capacity 3 Planks (lbs.)	Estimated Air Flow Per Plank (SCFM)					PSI Min.	Weight (lbs.)
				Steel	Epoxy Floor	Poor Concrete	Good Concrete	Great Concrete		
AF04012-XXXX	9,000	18,000	27,000	16.2	20.3	40.5	32.4	24.3	34	60-100
AF04017-XXXX	18,000	36,000	54,000	24.0	30.0	60.0	48.0	36.0	35	80-120
AF04020-XXXX	25,000	50,000	75,000	27.0	33.8	67.5	54.0	40.5	36	90-150
AF04024-XXXX	37,500	75,000	112,000	33	41.25	82.5	66	49.5	36	130-200

3. SETUP INSTRUCTIONS

⚠ WARNING

To Prevent serious injury or death.

Use properly rated lifting equipment to move and install equipment.

Each plank is equipped with four [4] 3/8"-16 threaded lifting holes located on the top surface, for crane lifting. Planks may be lifted by hand depending on the size, check sales drawing to confirm weight before attempting.

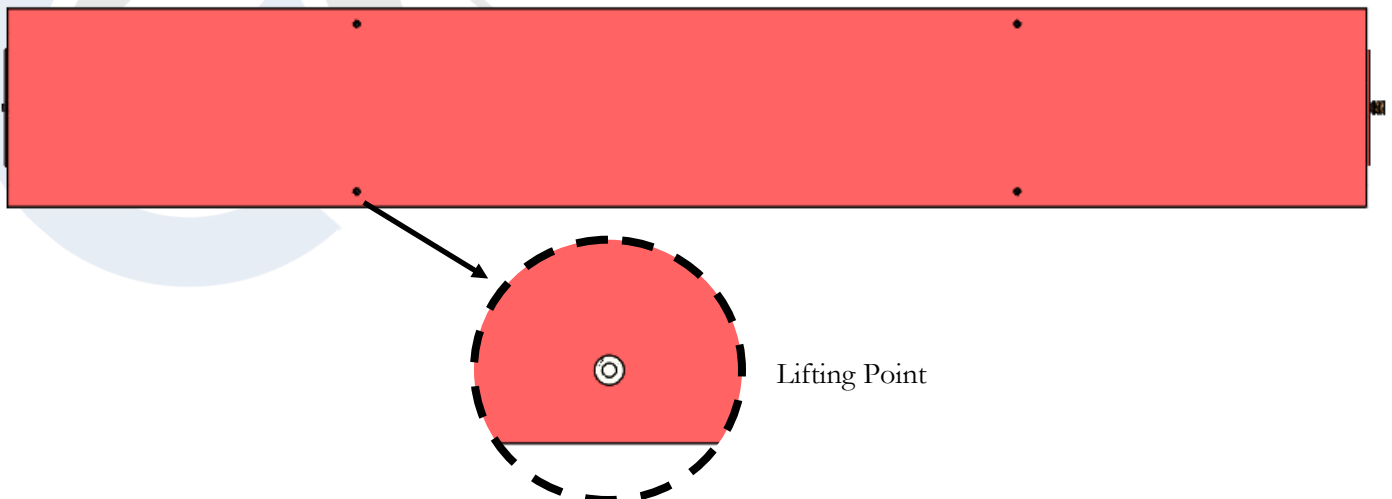

3. SETUP INSTRUCTIONS (CONT.)

3.1 POSITIONING THE PLANKS/WORKPIECE

- 1) Arrange the planks so that the weight of the workpiece will be equally distributed.
- 2) Connect the air bearing supply line to each plank.
NOTE: Each supply line is approximately 15 feet long. (SOLD SEPARATE)
- 3) Load the workpiece onto the plank system.
- 4) Connect the main air supply to the 3/4" FNPT connection on the pendant controller. **(SOLD SEPERATLY)**
- 5) Actuate the air bearing deadman control and use the air bearing supply valve to adjust the airflow to the air bearings to achieve desired flotation.
NOTE: Each plank has its own flow control valve on the pendant to more accurately adjust the airflow.

If no option for controls is selected, the recipient of the equipment will be responsible for air preparation and control.

- 6) Position/move the plank/workpiece system to the desired location and then release the air bearing deadman to deflate the air bearings.
- 7) When moving is complete, reverse steps 2-5 to transport to the next desired location

4. OPERATING INFORMATION

4.1 OPERATIONAL CONTROLS

The equipment is operated using the following controls...

- **Control Pendant:** Ball valve used to control air supply to the pendant.
- **Air Bearing Supply:** Flow controls located on the control pendant is used to regulate the amount of air to the bearings.
- **Air Bearing Deadman:** Handheld deadman connected to the pendant controller used to inflate air bearings.
NOTE: The air bearings will only be active while the deadman is pressed and held.
- **Customer Supplied:** If no option for controls is selected, the recipient of the equipment will be responsible for air preparation and control.

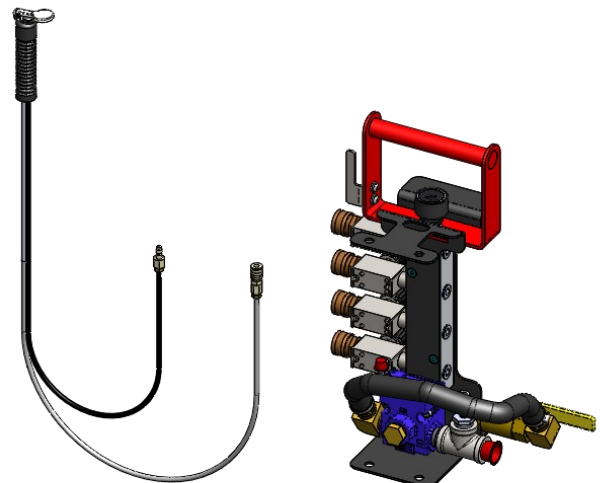

5. SERVICE AND MAINTENANCE

5.1 MAINTENANCE SCHEDULE

To keep your equipment operating correctly and reliably, please review the recommended service and maintenance schedule below and use the information to create a PM schedule.

Interval	Inspection	Corrective Action
1 Month	Inspect Pneumatic Hoses	Inspect all pneumatic hoses for damage and repair or replace as necessary.
1-3 Months	Inspect Hardware Connections	Inspect hardware locations for loose connections and to ensure the bearings is properly secured to the plank. Tighten as necessary.
3-6 Months	Inspect Air Bearings	Inspect air bearings for any tears and dirt build-up.

5.2 MAINTENANCE HELP

The equipment was designed to help ease service and maintenance.

5.2.1 AIR BEARING REPLACEMENT

1. Remove the bolt, lock washers, and the end plates that hold the bearing in place. Then slide the air bearing tray out of the slots.

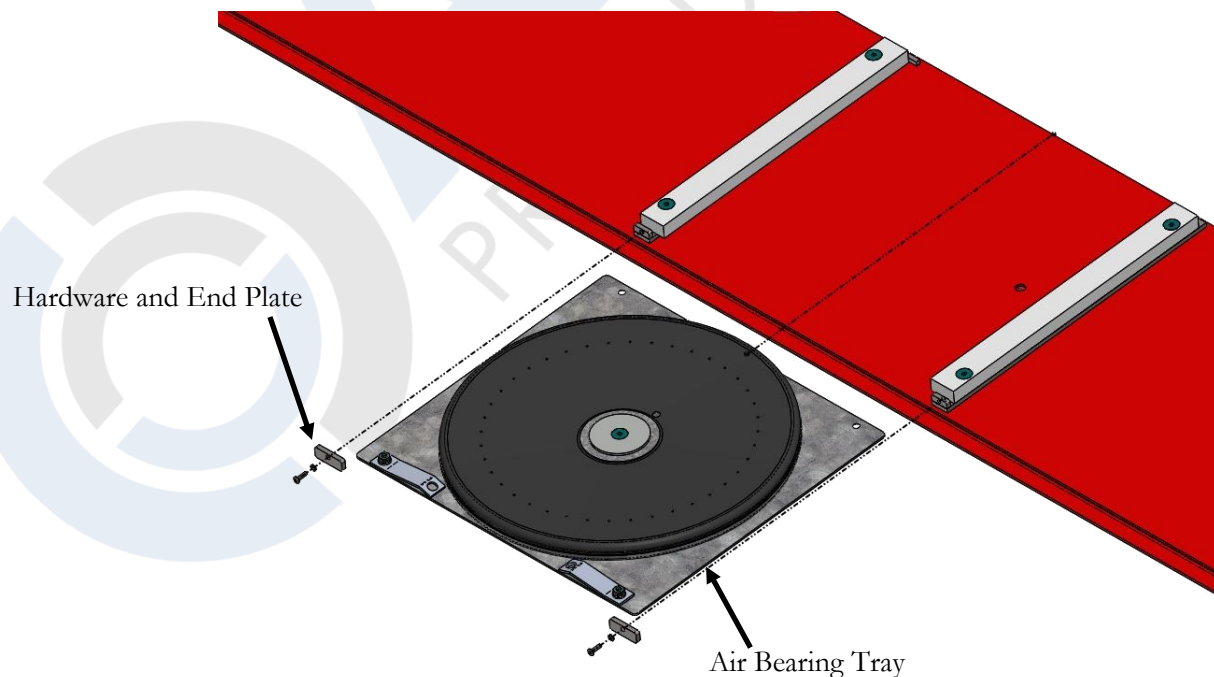

Figure 1: Sliding out the Air bearing Tray

6. TROUBLESHOOTING

Problem	Cause	Solution
Workpiece will not lift or is difficult to move	Too much weight	Ensure the equipment capacity has not been exceeded. Lighten load.
	Surface too rough for the air supply (insufficient air flow)	Ensure floor is within specification
One corner of the load is low or drags	Too much restriction to that air bearing	Increase flow control valve setting
	Torn or damaged diaphragm	Replace air bearing
	Dirt or object clinging to diaphragm	Replace diaphragm
	Low corner more heavily loaded than others	Increase air flow to low corner or reduce flow to others
Load rocks	Individual flow controls too restricted	Open individual flow controls and reduce inlet pressure
Load hops	Excess air is being supplied	Decrease air flow

7. SPARE PARTS

Part Number	Description	Quantity
H-XXXX	AIR BEARING / HIGH PERFORMANCE	3
VAP-127010401	BALL VALVE / 3/4 IN / VENTED	1
VSD8008	FLOW CONTROL VALVE / 1/2 NPT	4
QDAFS0850MS	QUICK DISCONNECT / 1/2 IN	1
PTT-14406-RDT	UHMW REST PAD	6

To reorder a part, please call **1-800-888-0018** and ask for the Parts Department. If possible, please have your equipment serial number handy for reference.

