

4

3

2

1

REVISIONS

ZONE	REV.	DESCRIPTION	DATE	REV. BY

INLET SEAL

HANDLE

SUPPLY HOSE

OUTLET HOSE
PENDANT

CONTROLLER

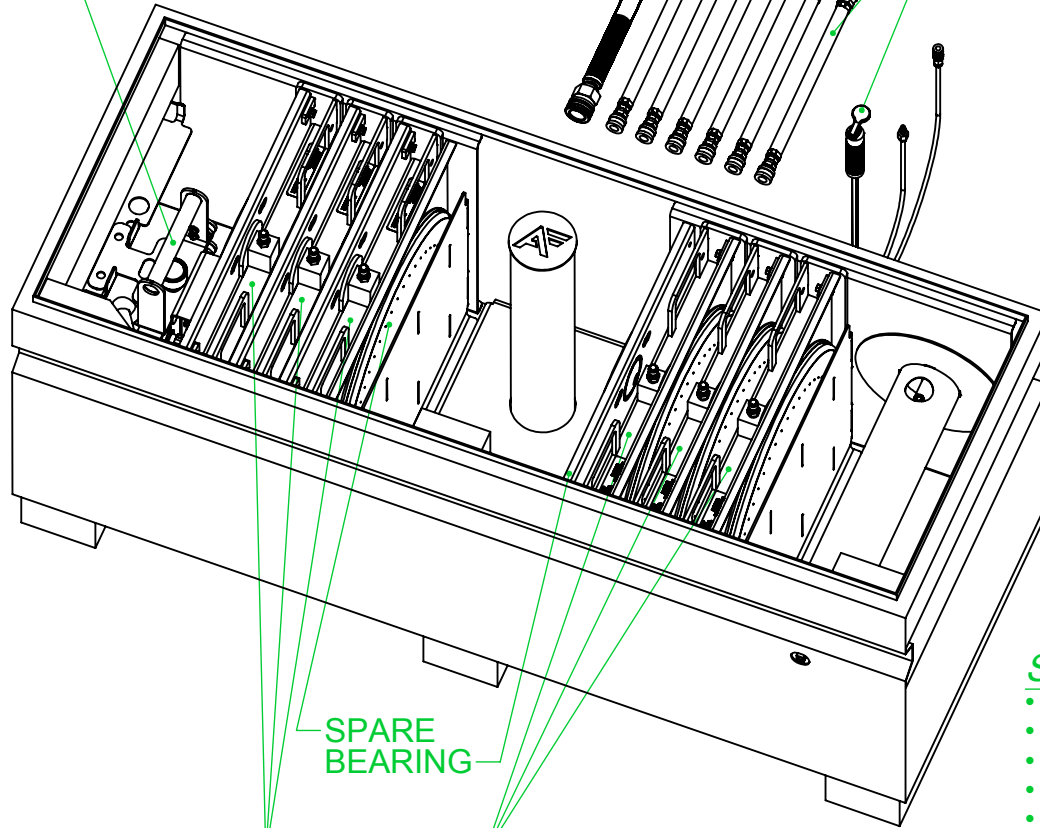

SPARE BEARING

AIR SKIDS

Contents:

- (6) AF01020A-1 AIR SKIDS
- (2) K20-0009 SPARE AIR BEARINGS
- (1) AF5017/AF5018 CONTROLLER
- (6) AF5105 OUTLET HOSES
- (1) AHA0083 SUPPLY HOSE (3/4" DIA.)
- (1) PEN0057 PENDANT
- (1) ASY0432 HANDLE
- (2) REPLACEMENT INLET SEALS

Specifications:

- SYSTEM CAPACITY: 52,500 LBS (23,800 KG)
- SKID SIZE: 21-1/2" X 21-1/4" X 3" (546mm x 540mm x 76mm)
- OVERALL SIZE: 60" X 24" X 28-1/4"
- SKID AIR INLET: 3/8" NPT
- AIR BEARING LIFT: 3/8" (9.5mm)
- AIR BEARING: H-0020 20" (508mm)
- AIR FLOW: 108 SCFM (51 L/s) (DEPENDING ON FLOORS)

A

UNLESS OTHERWISE SPECIFIED DIMENSIONS ARE IN INCHES TOLERANCES ARE: FRACTIONS: ± 1/16 DECIMALS: .XX ± .03 ANGULAR: .XXX ± .010 ± 1° DO NOT SCALE DRAWINGS	WORK ORDER #		ROUTING			2230 Brush College Rd Decatur, IL 62526 www.alignproductionssystem.com sales@alignprod.com Phone: 217.423.6001				
	DRAWN	MLT	11/4/15			TITLE RIGGER BOX - (6)20" AIR SKIDS WITH CONTROLLER AND HOSES				
	THIS DRAWING CONTAINS INFORMATION PROPRIETARY TO ALIGN PRODUCTION SYSTEMS LLC AND SHALL NOT BE DISCLOSED FOR ANY PURPOSE NOR USED FOR MANUFACTURING PURPOSES WITHOUT THE WRITTEN PERMISSION OF ALIGN PRODUCTION SYSTEMS LLC.					SIZE	SCALE	DRAWING NO.	REV.	
TOTAL WT.		SHEET		SIZE		SCALE		DRAWING NO.		REV.
688.50 lbs		1 OF 1		A		1:8		C18-0006 SALES		--02

4

3

2

1