

4

3

2

1

REVISIONS

ZONE	REV.	DESCRIPTION	DATE	REV. BY
------	------	-------------	------	---------

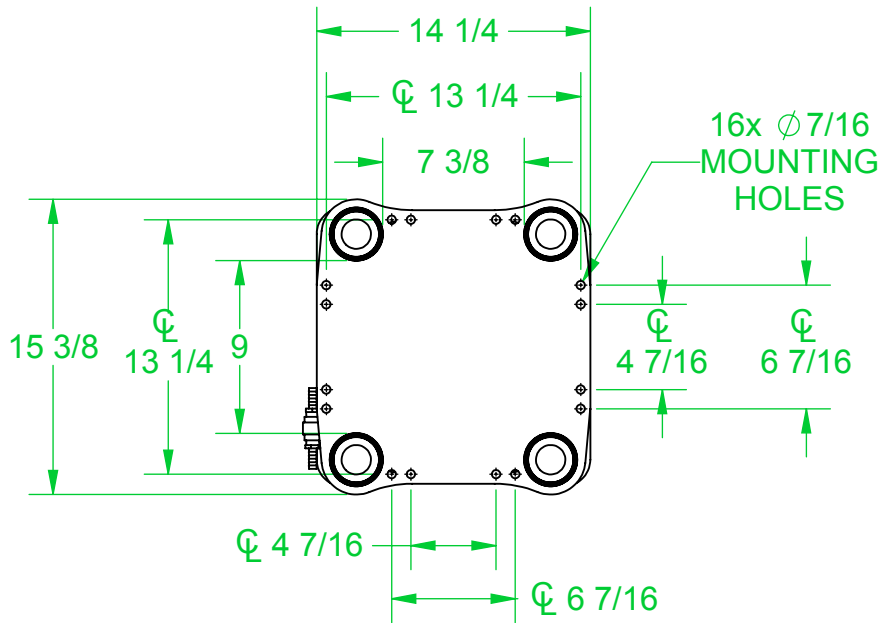

Specifications:

- LIFT GLIDE CAPACITY: 2500 LBS (1134 kg)
- SKID SIZE: 15.375" X 14.25" X 9.9375" (391 X 362 X 252 mm)
- MATERIAL: STEEL
- AIR BEARING LIFT: 1/4" (6.4 mm)
- MOUNTING HOLE SIZE: 7/16
- AIR BEARING: H-0012 12" (305 mm) Ø
- AIR FLOW: 11 SCFM (5.2 L/s) * PER UNIT
- AIR SUPPLY: 80 PSI
- SOLD IN SETS OF 4

2 7/8 STROKE

5 3/4

9 15/16

SKID AIR SUPPLY 3/8" HOSE BARB
 SPRING AIR SUPPLY 3/8" HOSE BARB

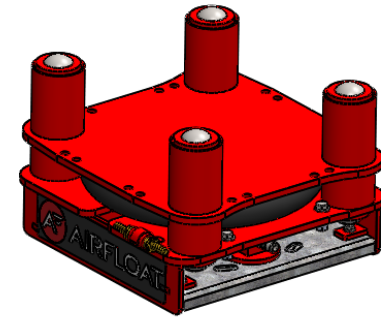

NOTE: DIMENSIONS ARE FOR REFERENCE ONLY, TOLERANCE BLOCK DOES NOT APPLY
 * BASED ON AVERAGE MACHINE TROWELED FINISHED CONCRETE

DISCARD ALL DRAWINGS AND/OR BILL OF MATERIALS ISSUED PRIOR TO

2/9/2015

USE PRINT WITH THE LATEST DATE FOR PRODUCTION

ENGR. APPROVAL _____

UNLESS OTHERWISE SPECIFIED DIMENSIONS ARE IN INCHES TOLERANCES ARE:

FRACTIONS: ± 1/16
 DECIMALS: .XX ± .03
 ANGULAR: ± 1°
 .XXX ± .010

DO NOT SCALE DRAWINGS

WORK ORDER #		ROUTING
		A
DRAWN	PAB	4/29/14

THIS DRAWING CONTAINS INFORMATION PROPRIETARY TO ALIGN PRODUCTION SYSTEMS LLC AND SHALL NOT BE DISCLOSED FOR ANY PURPOSE NOR USED FOR MANUFACTURING PURPOSES WITHOUT THE WRITTEN PERMISSION OF ALIGN PRODUCTION SYSTEMS LLC.



2230 Brush College Rd
 Decatur, IL 62526
 www.alignproductionssystem.com
 sales@alignprod.com
 Phone: 217.423.6001

TITLE LIFT GLIDE ASS'Y / 12" / 2500 LB CAPACITY

TOTAL WT.	SHEET	SIZE	SCALE	DRAWING NO.	REV.
97.20 lbs	1 OF 1	A	1:10	AF06012-1	B

4

3

2

1