

REVISIONS				
ZONE	REV.	DESCRIPTION	DATE	REV. BY

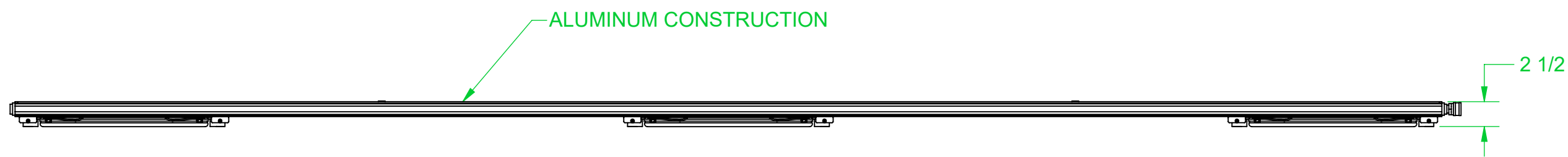

SPECIFICATIONS:

- CAPACITY: 19,000 lbs. PER PLANK
- REST HEIGHT: 2 1/2"
- INFLATED HEIGHT: 2 3/4" - 3 1/2"
- LENGTH: 72" MIN - 144" MAX (6" INCREMENTS)
- WIDTH: 18"
- WEIGHT: 80-120 lbs. DEPENDING ON LENGTH
- AIR BEARINGS: 3X 17" BEARINGS
- AIR REQUIREMENT: 24-65 SCFM @ 80 PSI, CLEAN AND DRY
- CONTROLS: STANDARD HAND HELD PENDANT (SOLD SEPERATE)

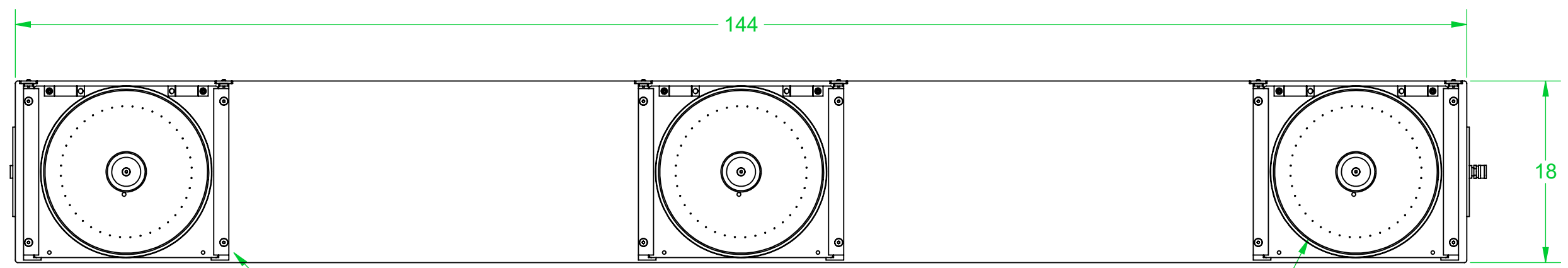

UHMW REST PAD

MAXIMUM LENGTH

3X 17" AIR BEARING

4X 3/8-16 LIFTING POINTS

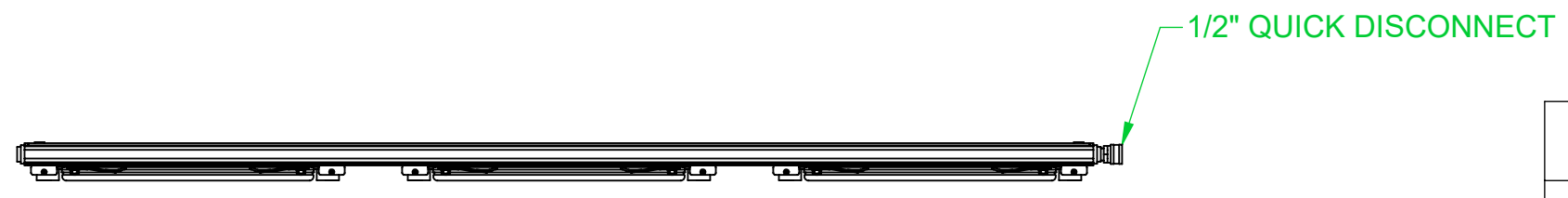
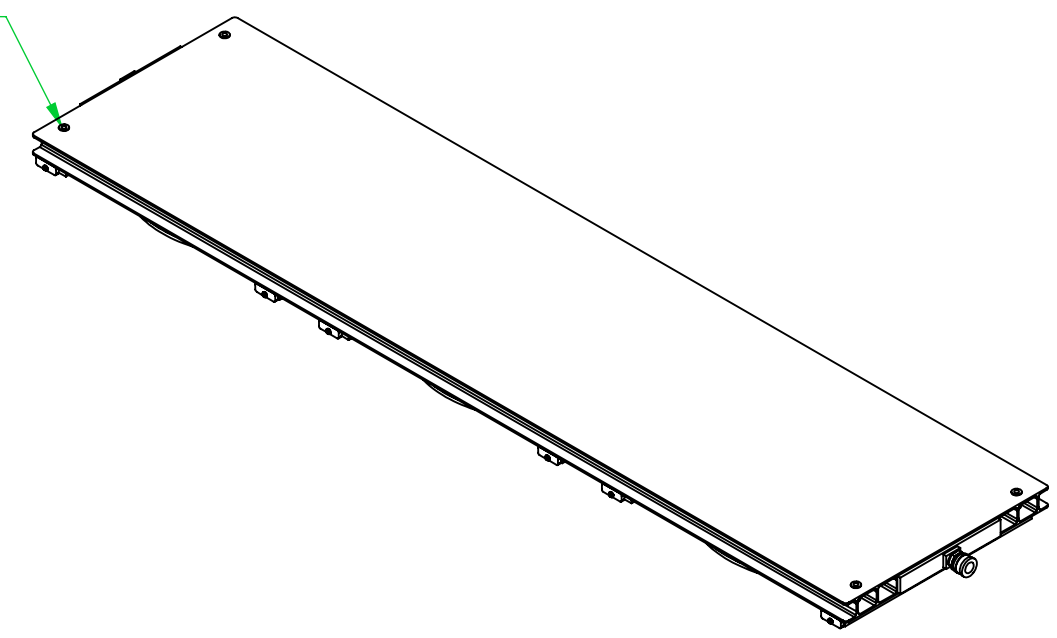

PART NUMBER	LENGTH (INCHES)
F04017-0001	72
F04017-0002	78
F04017-0003	84
F04017-0004	90
F04017-0005	96
F04017-0006	102
F04017-0007	108
F04017-0008	114
F04017-0009	120
F04017-0010	126
F04017-0011	132
F04017-0012	138
F04017-0013	144

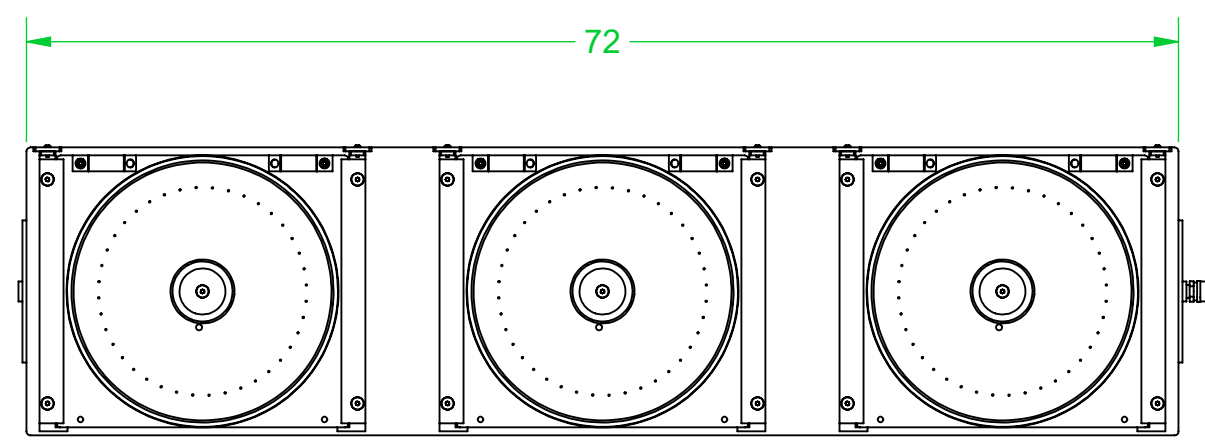

MINIMUM LENGTH

MINIMUM OF TWO PLANKS PER SYSTEM

NOTE: DIMENSIONS ARE FOR REFERENCE ONLY, TOLERANCE BLOCK DOES NOT APPLY

DISCARD ALL DRAWINGS AND/OR BILL OF MATERIALS ISSUED PRIOR TO
5/21/2019
 USE PRINT WITH THE LATEST DATE FOR PRODUCTION
 ENGR. APPROVAL _____

UNLESS OTHERWISE SPECIFIED DIMENSIONS ARE IN INCHES TOLERANCES ARE: FRACTIONS: ± 1/16 DECIMALS: .X ± .06 ANGULAR: .XX ± .02 ± 1° DO NOT SCALE DRAWINGS	WORK ORDER #	ROUTING		2230 Brush College Rd Decatur, IL 62526 www.alignproduction.com sales@alignprod.com Phone: 217.423.6001
	DRAWN	zoc		
THIS DRAWING CONTAINS INFORMATION PROPRIETARY TO ALIGN PRODUCTION SYSTEMS LLC AND SHALL NOT BE DISCLOSED FOR ANY PURPOSE NOR USED FOR MANUFACTURING PURPOSES WITHOUT THE WRITTEN PERMISSION OF ALIGN PRODUCTION SYSTEMS LLC.			TITLE	ALUMINUM AIR PLANK ASSEMBLY / 19K CAPACITY / 17" AIR BEARING / LENGTH IN INCREMENTS OF 6" [(LENGTH: 72 - 144)]
TOTAL WT.	SHEET	SIZE	SCALE	DRAWING NO.
154.09 lbs	1 OF 1	C	1:16	F04017-XXXX
				REV. --02